

# PARTS CATALOGUE



**SKYTEAM** ST50 / ST90



**SKY TEAM CORPORATION LTD.**

1104 CARNIVAL COMMERCIAL BLDG.  
18 JAVA ROAD NORTH POINT HONGKONG  
TEL:00852 25089428  
FAX:00852 25089478  
EMAIL:SKYTEAM\_HK@HOTMAIL.COM  
HTTP://WWW.SKYTEAM.NET.CN  
WWW.SKYTEAM.CN

# 前 言

用户订购零件时请参考本册，若与实车不同之处，以实车为准。如欲知某零部件的名称、件号或装配关系，可按零部件的形状，在有关的插图中查找，可知其装配位置。然后按图上的序号在相应的表格中即可查到零部件的名称、件号和数量。后续更改，不再通知。

## FOREWORD

Please make reference to this book when you plan to purchase the parts. Any difference against the real motorcycle, please do as per the real. To get information concerning a certain component part, first locate, by its shape, the part in the illustration which show its fitting position, then find out the reference number of that part and look it up the corresponding table where all information about the part are provided, such as the name, part number, quantity and/or its fitting relationship with other parts, Any modifications will not be informed ahead of time.

**ST50 ST90**

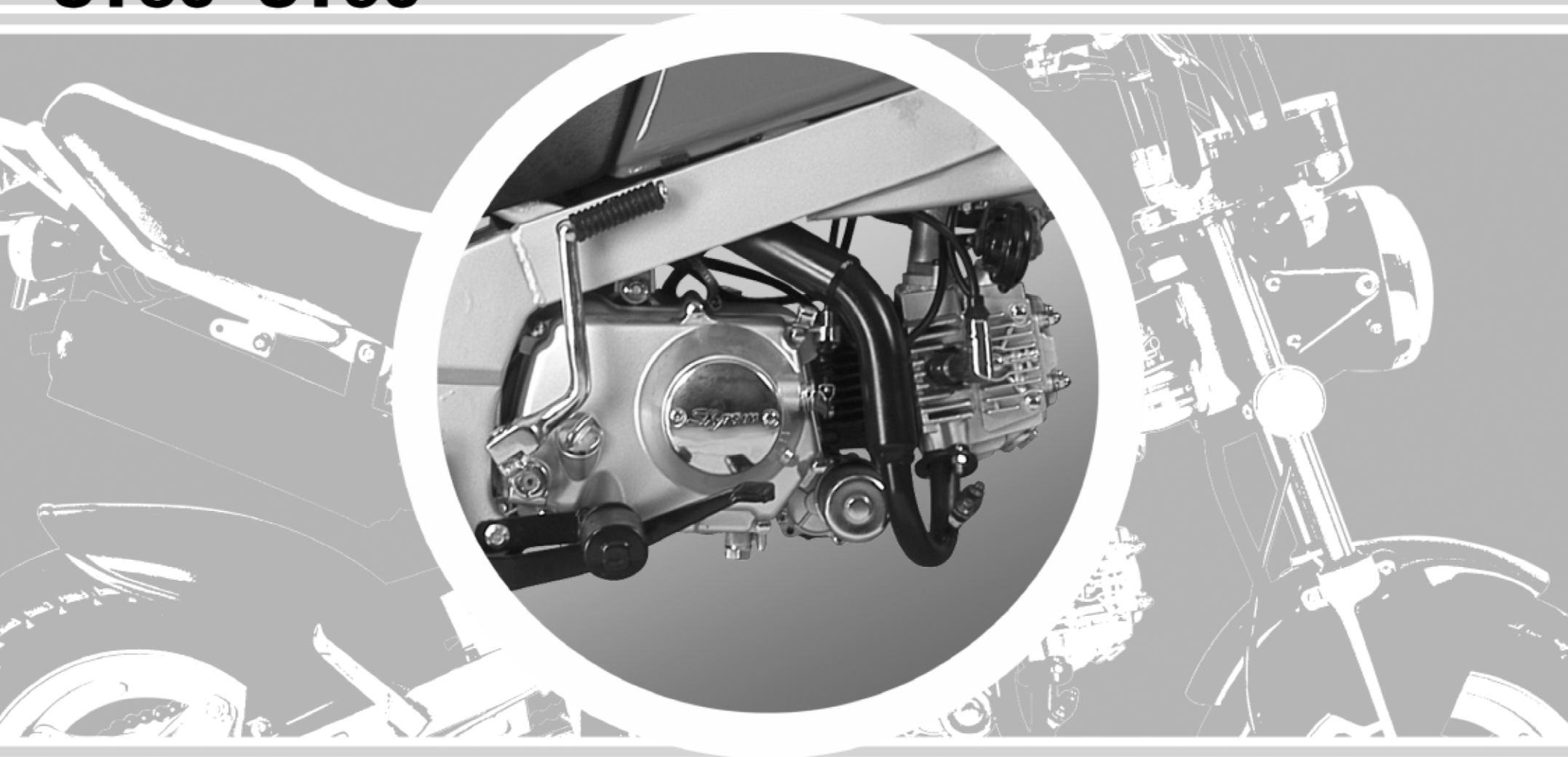

**PARTS CATALOGUE — ENGINE**



E-1 气缸、气缸头 (CYLINDER、CYLINDER HEAD)

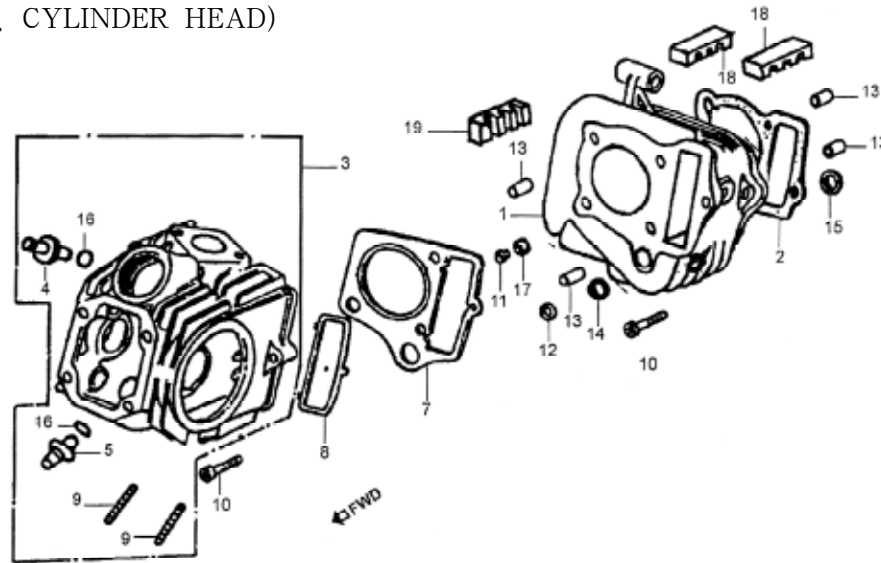

序号 Ref.No.	零部件代号 Part No.	零部件名称及规格	Part Name And Standard	数量 Quantity	备注 Remark
1	147FMF-2.01-2	气 缸	Cylinder(90cc)	1	
1-1	139FMA-2.01-2	气 缸	Cylinder(50cc)	1	
2	147FMF-2.01-1	气缸衬垫	Gasket, cylinder(90cc)	1	
2-1	139FMA-2.01-1	气缸衬垫	Gasket, cylinder(50cc)	1	
3	147FMF-2.01.04	气缸头组合	Head comp, cylinder(90cc)	1	
3-1	139FMA-2.01.04	气缸头组合	Head comp, cylinder(50cc)	1	
4	01.01.01.04	进气门导管	Guide, in. valve	1	
5	01.01.01.05	排气门导管	Guide, ex. valve	1	
7	147FMF-2.01.01	气缸头衬垫	Gasket, cylinder(90cc)	1	
7-1	139FMA-2.01.01	气缸头衬垫	Gasket, cylinder(50cc)	1	
8	01.01.04.03	时规链条腔密封环	Seal, cam chain chamber	1	
9	01.01.01.07	双头螺栓 M6 × 32	Bolt, stud, 6 × 32	2	
10	01.01.00.30	螺栓 M6 × 23	Bolt, hex, 6 × 23	1	
11	01.01.00.33	衬套 9.5mm	Collar, 9.5mm	1	
12	01.01.00.27	垫圈 14.8mm	Collar, 14.8mm	1	



E-1 气缸、气缸头 (CYLINDER、CYLINDER HEAD)

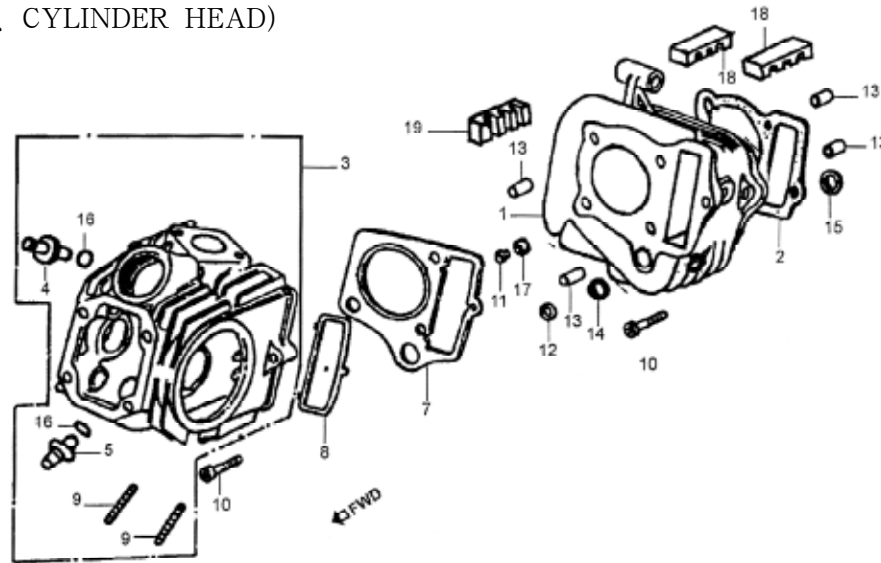

序号 Ref.No.	零部件代号 Part No.	零部件名称及规格	Part Name And Standard	数量 Quantity	备注 Remark
13	01.01.00.32	定位销 8 × 14	Pin, dowel, 8 × 14	4	
14	01.01.00.23	O型圈 14.5 × 2	O-ring, 14.5 × 2	1	
15	01.01.00.29	矩形圈 11.5 × 2.1	Packing, rubber, 11.5 × 2.1	1	
16	01.01.01.06	O型圈 9 × 1.6	O-ring, 9 × 1.6	2	
17	01.01.00.34	矩形圈 9 × 1.35	Gasket, rubber, 9 × 1.35	1	
18	01.01.00.98	减震块A	Block, vibration reduction	2	
19	01.01.00.99	减震块B	Block, vibration reduction	1	



E-2 气缸头盖 (CYLINDER、HEAD COVER)

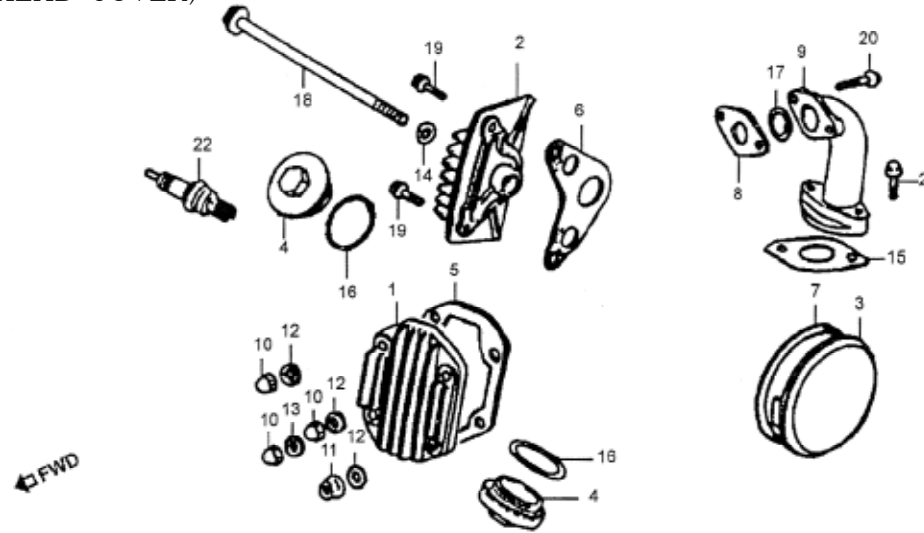

序号 Ref.No.	零部件代号 Part No.	零部件名称及规格	Part Name And Standard	数量 Quantity	备注 Remark
1	LC152FMH-2.01-40	气缸头盖	Cover, cylinder head	1	
2	LC152FMH-2.01.05	气缸头右盖	Cover, R. cylinder head side	1	
3	07.01.00.20	气缸头左盖	Cover, L. cylinder head side	1	
4	01.01.00.08	气门室盖	Cap, tappet adjusting hole	2	
5	LC152FMH-2.01-39	气缸头盖衬垫	Gasket, cylinder head cover	1	
6	LC152FMH-2.01-35	气缸头右盖衬垫	Gasket, R. cylinder head side cover	1	
7	01.01.00.21	气缸头左盖衬垫	Gasket, L. cylinder head side cover	1	
8	01.01.00.04-3	进气管隔热垫	Insulate(90cc)	1	
8-1	01.01.00.04-1	进气管隔热垫	Insulate(50cc)	1	
9	02.01.00.05-3	进气管	Pipe, in.(90cc)	1	
9-1	02.01.00.05-1	进气管	Pipe, in.(50cc)	1	
10	01.01.00.43	盖形螺母 M6	Nut, cap, 6mm	3	
11	01.01.00.43	盘形螺母 M6	Nut, flange, 6mm	1	
12	01.01.00.41	垫圈 6mm	Washer, sealing, 6mm	3	
13	01.01.00.42	垫圈 A6mm	Washer A, sealing, 6mm	1	



E-2 气缸头盖 (CYLINDER、HEAD COVER)

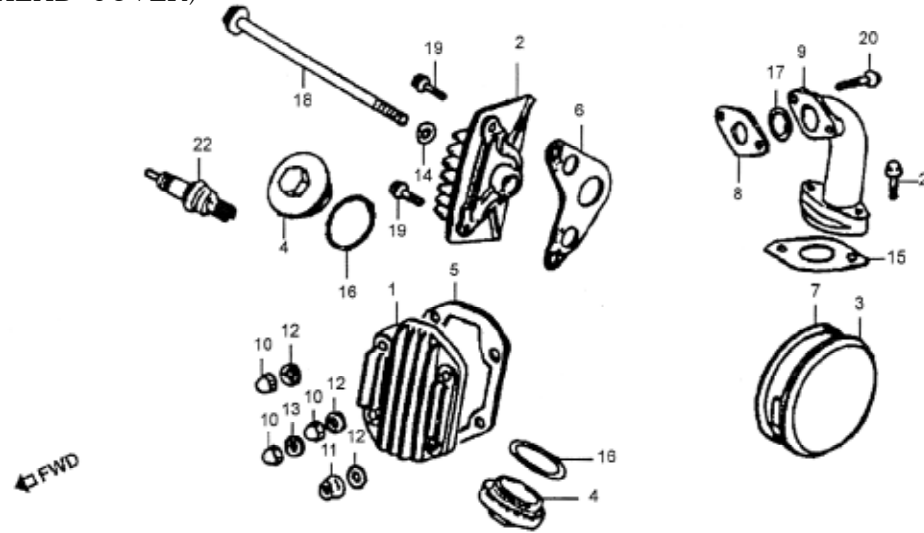

序号 Ref.No.	零部件代号 Part No.	零部件名称及规格	Part Name And Standard	数量 Quantity	备注 Remark
14	01.01.00.36	垫圈 6.5mm	Washer sealing, 6.5mm	1	
15	01.01.00.06-3	衬垫	Gasket, pipe, IN.(90cc)	1	
15-1	01.01.00.06-1	衬垫	Gasket, pipe, IN.(50cc)	1	
16	01.01.00.07	O形圈 30.8 × 3.2	O-ring, 30.8 × 3.2	2	
17	01.01.00.03	o形圈 25 × 2.4	O-ring, 25 × 2.4	1	
18	01.01.00.38	凸缘螺栓 M6 × 110	Block, flange, 6 × 110	1	
19	LC152FMH-2.01-2	凸形螺栓 M6 × 20	Bolt flange, 6 × 20	2	
20	LC152FMH-2.01-1	螺栓 M6 × 22	Bolt hex, 6 × 22	2	
21	LC152FMH-2.01.04	凸形螺栓 M6 × 28	Bolt, flange, 6 × 28	2	
22	01.01.01.04	火花塞 1137	Plug, spark(1137)	1	





E-3 气门组 (CAMSHAFT VALVE)

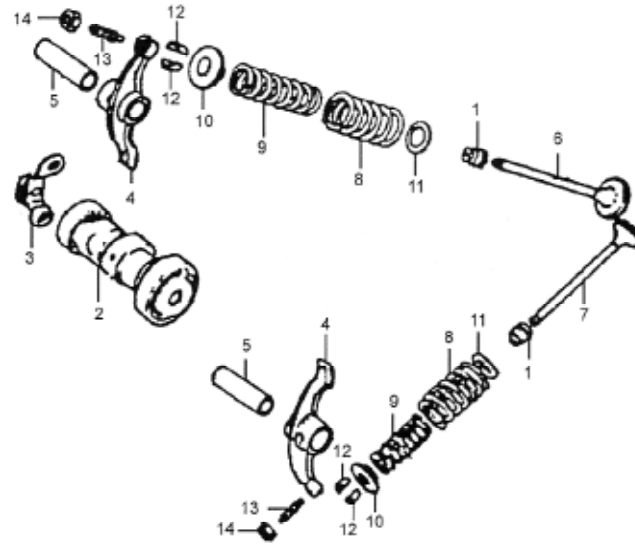

序号 Ref.No.	零部件代号 Part No.	零部件名称及规格	Part Name And Standard	数量 Quantity	备注 Remark
1	01.01.05.00	气门油封	Seal, valve stem	2	
2	07.01.03.00	凸轮轴组件	Cam shaft comp	1	
3	07.01.00.45	止动板	Valve stopper	1	
4	01.01.00.11	气门摇臂	Rocker arm	2	
5	01.01.00.12	摇臂轴	Shaft rocker arm	2	
6	01.01.00.13-3	进气门	Valve, inlet(90cc)	1	
6-1	01.01.00.13-1	进气门	Valve, inlet(50cc)	1	
7	01.01.00.14-3	排气门	Valve, exhaust(90cc)	1	
7-1	01.01.00.14-1	排气门	Valve, exhaust(50cc)	1	
8	01.01.11.16	气门外弹簧	Spring, valve outer	2	
9	01.01.00.17	气门内弹簧	Spring, valve inner	2	
10	01.01.00.18	气门内外弹簧座	Retainer	2	
11	01.01.00.15	气门外弹簧座	Seat outer	2	
12	01.01.00.19	气门锁夹	Cotter, valve	4	
13	01.01.00.10	气门间隙调整螺钉	Screw adjusting	2	
14	01.01.00.09	气门间隙锁紧螺母	Nut tappet adjusting	2	



E-4 链条及张紧装置 (CHAIN、CHAIN TENSIONER)

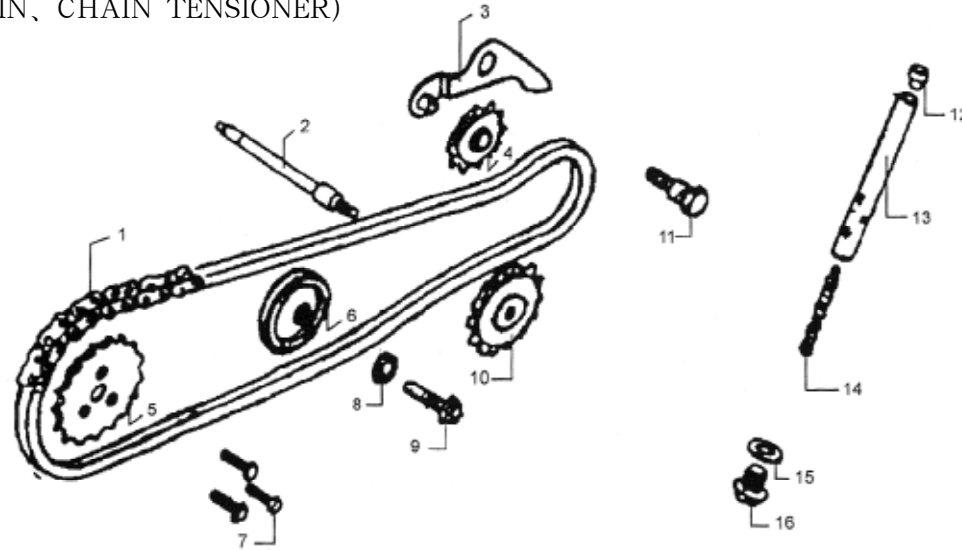

序号 Ref.No.	零部件代号 Part No.	零部件名称及规格	Part Name And Standard	数量 Quantity	备注 Remark
1	01.01.00.44	正时链条	Chain, cam	1	
2	01.04.00.07	油泵链轮轴	Spindle, cam chain guide sprocket	1	
3	01.04.09.00	张紧臂	Arm comp, cam chain tensioner	1	
4	01.04.10.00	张紧滚轮	Roller, cam chain tensioner	1	
5	01.01.00.22	正时从动链轮	Sprocket, cam	1	
6	01.01.06.01	导向滚轮	Roller comp, cam chain guide	1	
7	01.01.00.23	螺栓 M5 × 12	Bolt, knock 5 × 12	3	
8	01.01.00.25	垫圈 8mm	Washer, sealing 8mm	1	
9	01.01.00.24	导向滚轮销轴	Pin, cam chain guide roller	1	
10	01.04.05.00	油泵链轮	Sprocket, cam chain guide	1	
11	01.04.00.25	张紧臂芯轴	Pivot, cam chain tensioner	1	
12	01.04.00.16	堵头	Head, cam chain tensioner push rod	1	
13	01.04.07.00	张紧杆	Rod comp, cam chain tensioner push	1	
14	01.04.00.15	张紧杆弹簧	Spring, cam chain tensioner	1	
15	01.04.00.14	垫圈 14mm	Washer, sealing 14mm	1	
16	01.04.00.13	螺塞 M14 × 1.5	Bolt, sealing 14 × 1.5	1	



E-5 磁电机、左曲轴箱盖 (GENERATOR, L, CRANKCASE COVER)

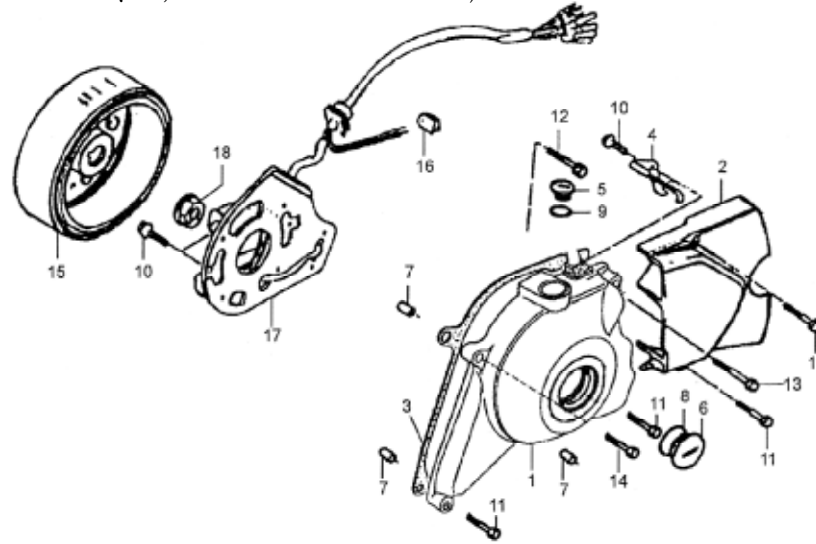

序号 Ref.No.	零部件代号 Part No.	零部件名称及规格	Part Name And Standard	数量 Quantity	备注 Remark
1	02.02.06.00	左曲轴箱前盖	Cover, L crankcase	1	
2	02.02.00.01	左曲轴箱后盖	Cover, L Crankcase, RR	1	
3	02.02.06.06	左曲轴箱盖密封垫	Gasket, L grankcase	1	
4	02.09.00.01	磁电机线夹	Clamper, wire harness	1	
5	02.02.06.04	视孔盖 B	Cap B	1	
6	02.02.06.02	视孔盖 A	Cap A	1	
7	01.01.00.31	定位销 8 × 12	Pin dowel 8x12	2	
8	02.02.06.03	O形圈 27 × 2.0	O-ring 27 × 2.0	1	
9	02.02.06.05	O形圈 13.8 × 2.5	O-ring 13.8 × 2.5	1	
10	GB18-86	凸缘螺栓 M6 × 16	Bolt, flange 6 × 16	3	
11	01.00.00.01	凸缘螺栓 M6 × 28	Bolt, flange 6 × 28	3	
12	02.00.00.03	凸缘螺栓 M6 × 32	Bolt, flange 6 × 32	1	
13	01.04.00.21	凸缘螺栓 M6 × 50	Bolt, flange 6 × 50	1	
14	02.00.00.02	凸缘螺栓 M6 × 70	Bolt, flange 6 × 70	1	
15	02.09.07.01	飞轮	Flywheel COMP	1	



E-5 磁电机、左曲轴箱盖 (GENERATOR, L, CRANKCASE COVER)

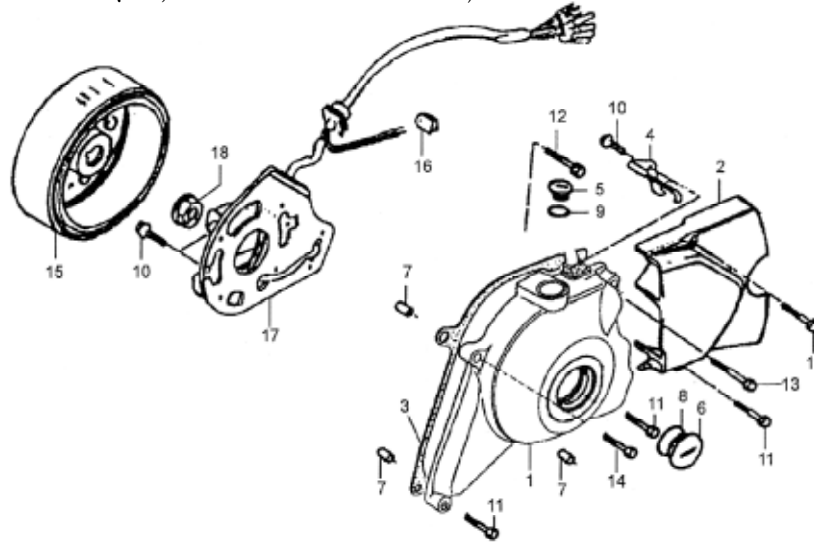

序号 Ref.No.	零部件代号 Part No.	零部件名称及规格	Part Name And Standard	数量 Quantity	备注 Remark
16	02.09.01.99	空档开关索环	Rubber,neutral switch cord	1	
17	02.09.01.00	定子组件	Stator comp	1	
18	02.09.01.98	凸缘螺母M10	Nut, flange 10mm	1	



E-6 电起动装置 (ELECTRIC STARTER)

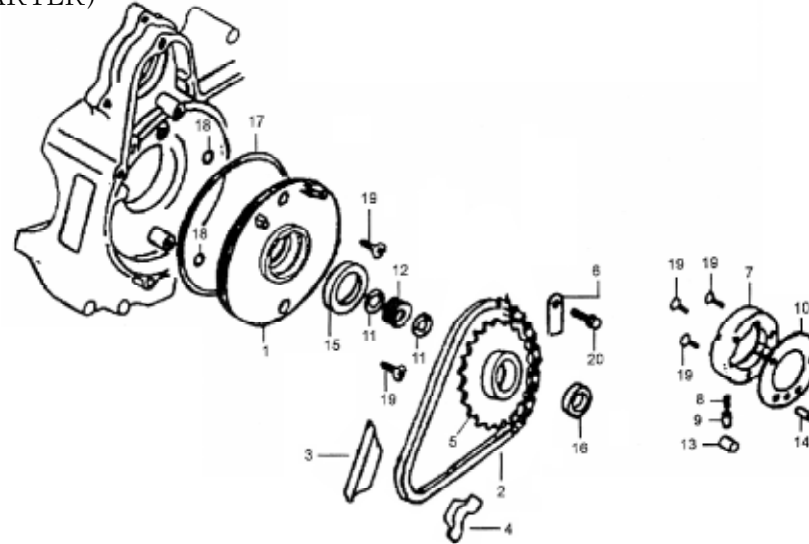

序号 Ref.No.	零部件代号 Part No.	零部件名称及规格	Part Name And Standard	数量 Quantity	备注 Remark
1	02.04.15.01	隔油盘	Plate, oil separator	1	
2	02.00.04.00	起动链条	Start chain	1	
3	02.04.02.04	起动链条导向板	Plate, guide chain	1	
4	02.04.02.05	起动链条护板	Plate, protect chain	1	
5	02.00.01.00	起动链轮组件	Start chain comp	1	
6	02.07.01.10	起动链轮定位板	Plate, set chain	1	
7	02.00.03.00	起动离合器壳体组件	Starter clutch outer assy	1	
8	02.00.03.01	离合器滚柱弹簧	Spring, clutch roller	3	
9	02.00.03.02	弹簧顶销	Pin, spring	3	
10	02.00.03.08	起动离合器侧板	Side plate, starter clutch	1	
11	9243/23.1	档圈 23mm	Circlip 23mm	2	
12	8x10III+3/30 GB4661-84	滚针轴承 19 × 23 × 13	Needle bearing 19 × 23 × 13	1	
13	02.00.03.03	离合器滚柱 10 × 10	Clutch roller 10 × 10	3	
14	02.00.03.04	销轴 5 × 11.8	Pin 5 × 11.8	1	
15	02.04.15.02	油封 30 × 42 × 4.5	Oil seal 30 × 42 × 4.5	1	



E-6 电起动装置 (ELECTRIC STARTER)

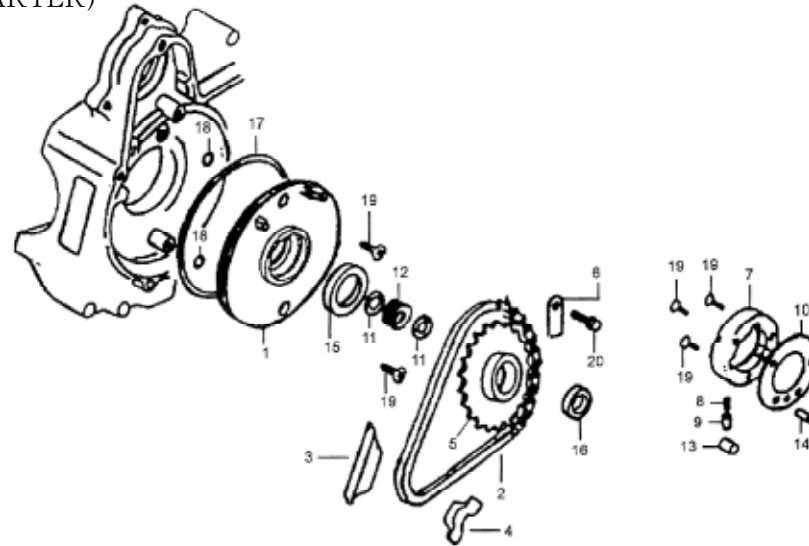

序号 Ref.No.	零部件代号 Part No.	零部件名称及规格	Part Name And Standard	数量 Quantity	备注 Remark
16	01.09.02.00	油封 18.9 × 28 × 5	Oil seal 18.9 × 28 × 5	1	
17	01.09.01.02	O 形圈 107 × 2	O-ring 107 × 2	1	
18	01.04.00.08	O 形圈 6 × 1.7	O-ring 6 × 1.7	2	
19	GB819-86	螺钉 M6 × 16	Screw 6 × 16	3	
20	GB818-86	螺钉 M6 × 10	Screw 6 × 10	1	



E-7 右边盖 (RIGHT COVER)

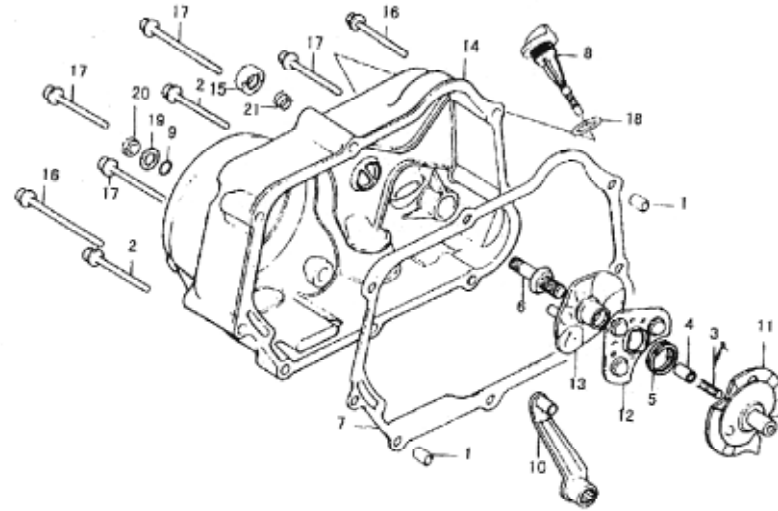

序号 Ref.No.	零部件代号 Part No.	零部件名称及规格	Part Name And Standard	数量 Quantity	备注 Remark
1	100027	定位衬套	DOWEL PIN	2	
2	M6 × 65 HwMHWZn	六角垫圈螺栓	SCREW	2	
3	130013	回转体中心弹簧	SPRING	1	
4	130014	回转体中心套	ROTART BODY CENTER BUSH	1	
5	130015	分离弹簧	SPRING	1	
6	130016	分座螺钉	SCREW	1	
7	130017C	右盖密封垫	R.CASE COVER GASKET	1	
8	130018	油标盖	OIL LEVER	1	
9	130022	O形封严圈	GAUGE	1	
10	130500	拨杆组件	LEVER COMP	1	
11	130600	拨杆回转体组件	LEVER AND ROTARY BODY COMP	1	
12	130700	滚珠架组件	BALL-RACE COMP	1	
13	130800	回转体支座组件	SUPPORT COMP,ROTARY BODY	1	
14	130900	机匣右盖组件	R,CASE COVER COMP	1	
15	130100	传动轴端皮碗	OIL SEAL	1	



E-7 右边盖 (RIGHT COVER)

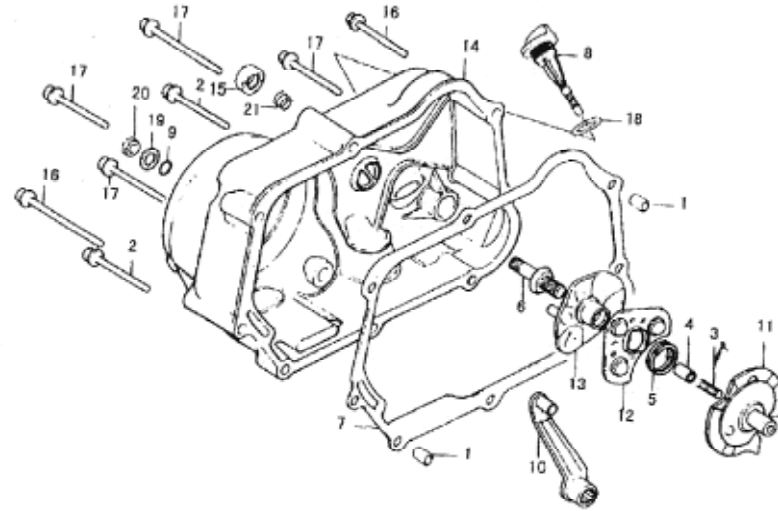

序号 Ref.No.	零部件代号 Part No.	零部件名称及规格	Part Name And Standard	数量 Quantity	备注 Remark
16	M6 × 35 HwMHWZn	六角垫圈螺栓	BOLT	2	
17	M6 × 40 HwMHWZn	六角垫圈螺栓	BOLT	4	
18	7D17-J7-18.5-2.6	O形封严圈	O-RING	1	
19	GB848-85 8-140HV-Zn.D	小垫圈	WASHER	1	
20	GB6170-86 M8-8-Zn.D	六角螺母	NUT	1	





E-8 右曲轴箱盖 (RIGHT CRANKCASE COVER)

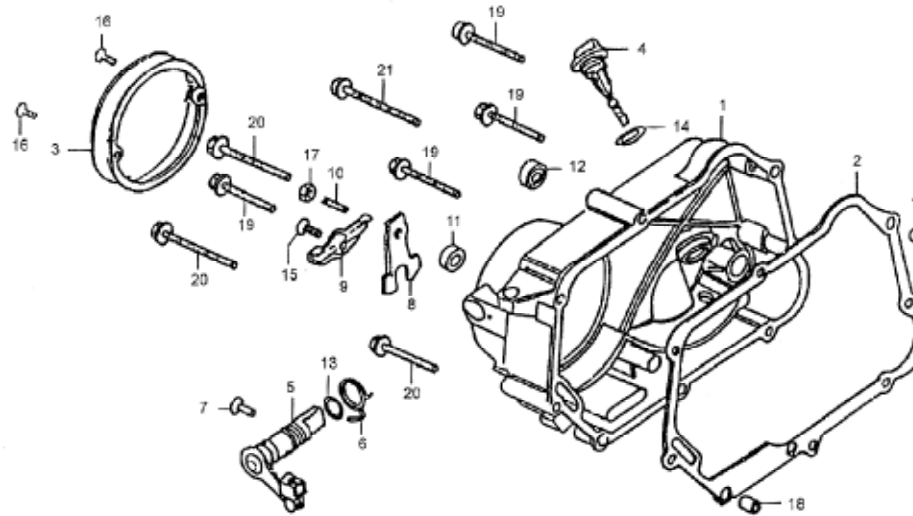

序号 Ref.No.	零部件代号 Part No.	零部件名称及规格	Part Name And Standard	数量 Quantity	备注 Remark
1	LX147FM-I.07.01	右曲轴箱盖	Cover comp, R. crankcase	1	
2	LX147FM.07-2	右曲轴箱盖密封垫	Gasket R cover	1	
3	LX150FM.07-6	离合器盖	Cover clutch	1	
4	LX150FM-I.07-11	机油标尺	Oil level meter	1	
5	LX150FM-I.07.02	离合器凸轮轴组件	Tappet	1	
6	LX147FM.07-3	离合器凸轮轴弹簧	Tappet spring	1	
7	LX147FM.07-5	离合器凸轮轴定位销	Tappet pin	1	
8	LX147FM.07-8	离合器拨板	Plate	1	
9	LX147FM.07-10	离合器压板	Plate	1	
10	LX147FM.07-9	调整螺钉	Adjusting screw	1	
11	LX147FM.07.04	油封	Seal ring	1	
12	LX147FM.07.05	油封	Seal ring	1	
13	LX147FM.07-4-	O型密封圈	O-ring	1	
14	LX147FM.07-12	O型密封圈	O-ring	1	
15	GB819-85	螺钉M6 × 16	Screw M6 × 16	1	



E-8 右曲轴箱盖 (RIGHT CRANKCASE COVER)

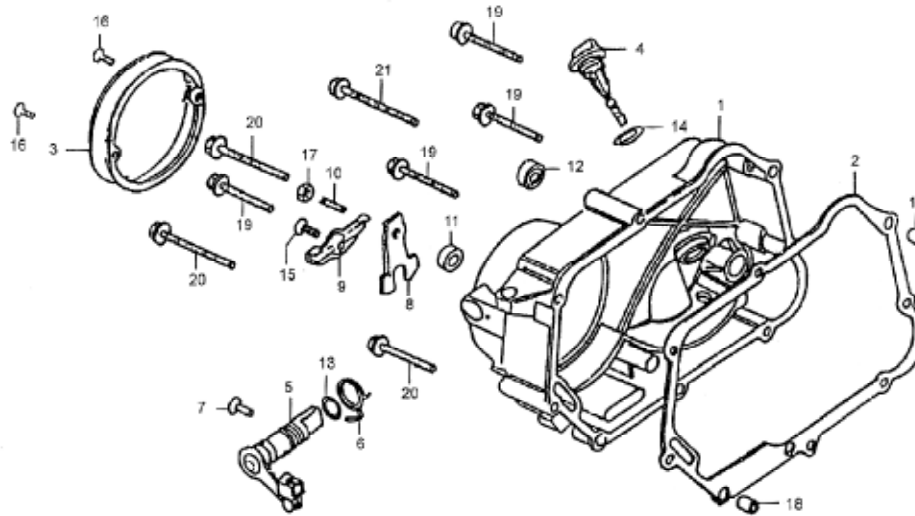

序号 Ref.No.	零部件代号 Part No.	零部件名称及规格	Part Name And Standard	数量 Quantity	备注 Remark
16	GB819-85	螺钉 M5 × 16	Screw M5 × 16	2	
17	GB6172-86	螺母	Nut	1	
18	LX147FM.01-31	定位销	Pin	2	
19	JH70.20016	螺栓 M6 × 40	Bolt M6 × 40	5	
20	JH70.20017	螺栓 M6 × 80	Bolt M6 × 80	1	
21	JH70.20018	螺栓 M6 × 65	Bolt M6 × 65	2	



E-9 离合器 (CLUTCH)

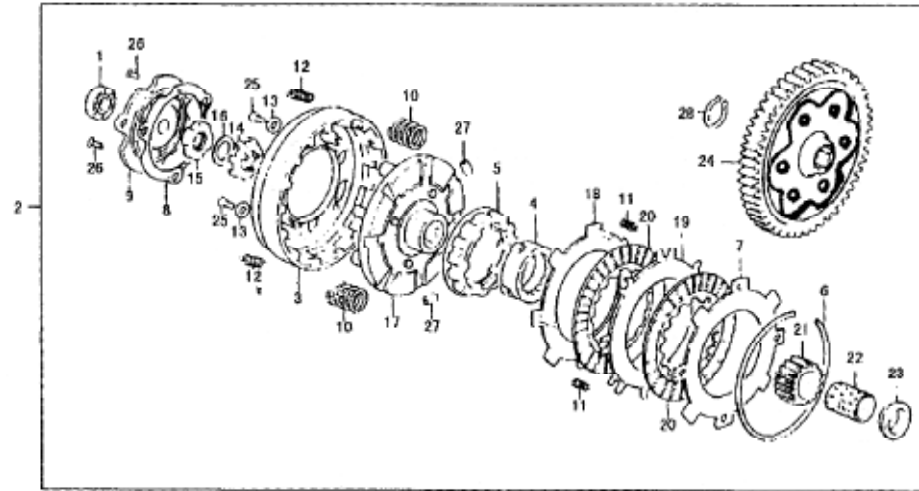

序号 Ref.No.	零部件代号 Part No.	零部件名称及规格	Part Name And Standard	数量 Quantity	备注 Remark
1	100 GB276-64	滚珠轴承	BEARING	1	
2	130000-1C	离合器组件	CLUTCH ASSY	1	
3	130001	离合器外壳	CLUTCH SHELL	1	
4	130002	传动轴外套	CLUTCH OUTER	1	
5	130003	传动轴外套	CLUTCH CENTER	1	
6	130004	卡圈	SETRING	1	
7	130005	摩擦前垫圈	WASHER	1	
8	130007	密封垫	GASKET	1	
9	130008	前盖	COVER	1	
10	130009	压紧弹簧	SPRING	2	
11	130010	自松弹簧	SPRING	2	
12	130011	缓冲弹簧	SPRING	2	
13	130012	垫片	WASHER	2	
14	130019	锁片	LOCKER	1	
15	130020	圆扁螺母	NUT	1	



E-9 离合器 (CLUTCH)

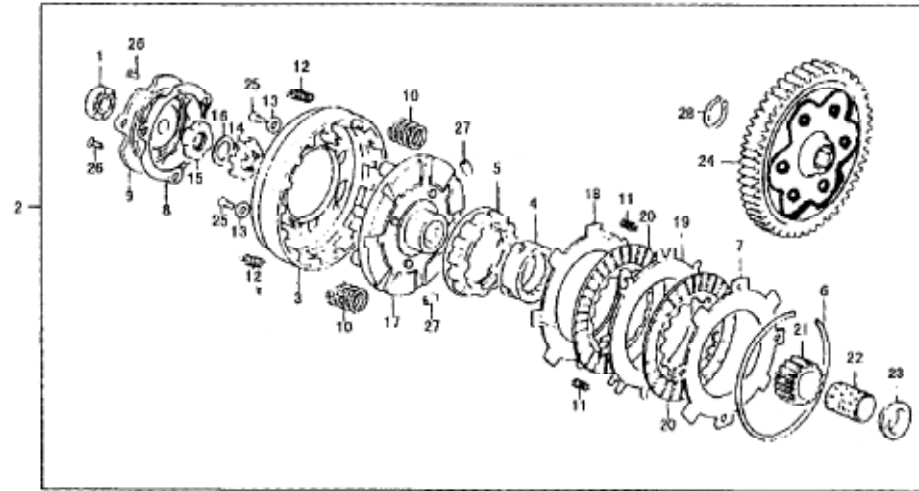

序号 Ref.No.	零部件代号 Part No.	零部件名称及规格	Part Name And Standard	数量 Quantity	备注 Remark
16	130021	碟形垫圈	SAUCER WASHER	1	
17	130100	离合器架组件	CLUTCH HOLDER	1	
18	130200	摩擦后垫片组件	WASHER	1	
19	130300A	外摩擦片组件	OUTER DISK CLUTCH FRICTION	1	
20	130400A	内摩擦片组件	CLUTCH FRICTION	2	
21	140001	曲轴齿圈	PRIMARY DRIVE GEAR	1	
22	140002	齿圈衬套	GUIDE	1	
23	140003	端面支撑面	COLLAR	1	
24	140100	中间齿轮组合	PRIMARY DRIVEN GEAR	1	
25	M5 × 10 GB818-76-35-Zn.D	十字槽平圆头螺钉	SCREW	2	
26	M5 × 10 GB819-76-35-Zn.D	十字槽沉头螺钉	SCREW	2	
27	8 × 10III+3/30 GB4661-84	圆柱滚子	ROLLER	2	
28	150003	卡圈	SETRING	1	



E-10 离合器 (CLUTCH)

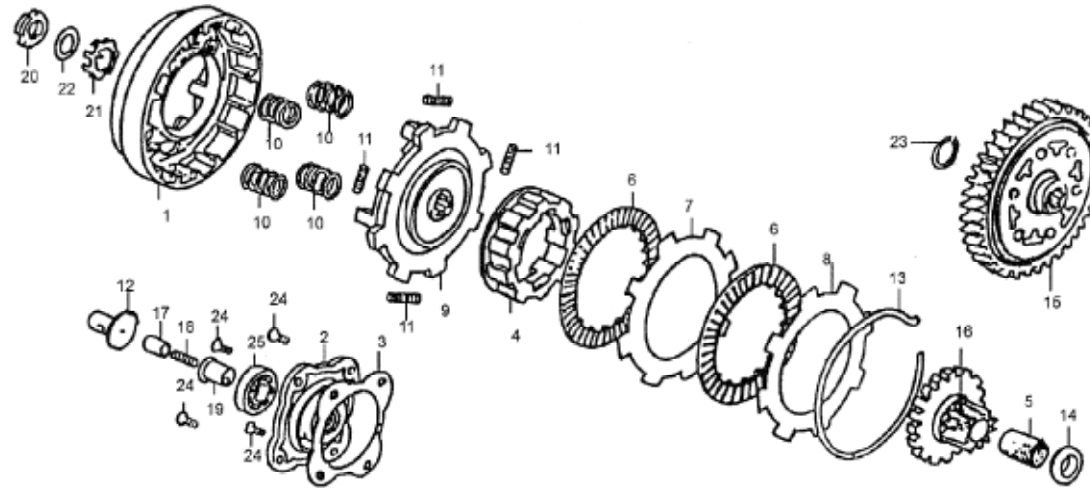

序号 Ref.No.	零部件代号 Part No.	零部件名称及规格	Part Name And Standard	数量 Quantity	备注 Remark
1	LX147FM.06-9	离合器外罩	Clutch cover	1	
2	LX147FM.06-15	离合器端盖	Plate, clutch lifter	1	
3	LX147FM.06-14	离合器端盖密封垫	Gasket	1	
4	LX147FM.06-4	主动齿轮外套	Driving gear cover	1	
5	LX147FM.06-2	轴套	Bush	1	
6	LX147FM.06.01	摩擦盘	Friction plate	2	
7	LX147FM.06-7	离合器下板	Up plate	1	
8	LX147FM.06-5	离合器上板	Down plate	1	
9	LX147FM.06-8	主动盘	Driving gear	1	
10	LX147FM.06-10	弹簧	Spring	4	
11	LX147FM.06-19	离合器减震簧	Damper spring	4	
12	LX147FM.07.03	离合器推杆组件	Clutch lever	1	
13	LX147FM.06-6	弹性挡圈	Spring washer	1	
14	LX147FM.06-1	套圈	Washer	1	
15	LX147FM.05.03	从动齿轮组件	Driven gear comp	1	



E-10 离合器 (CLUTCH)

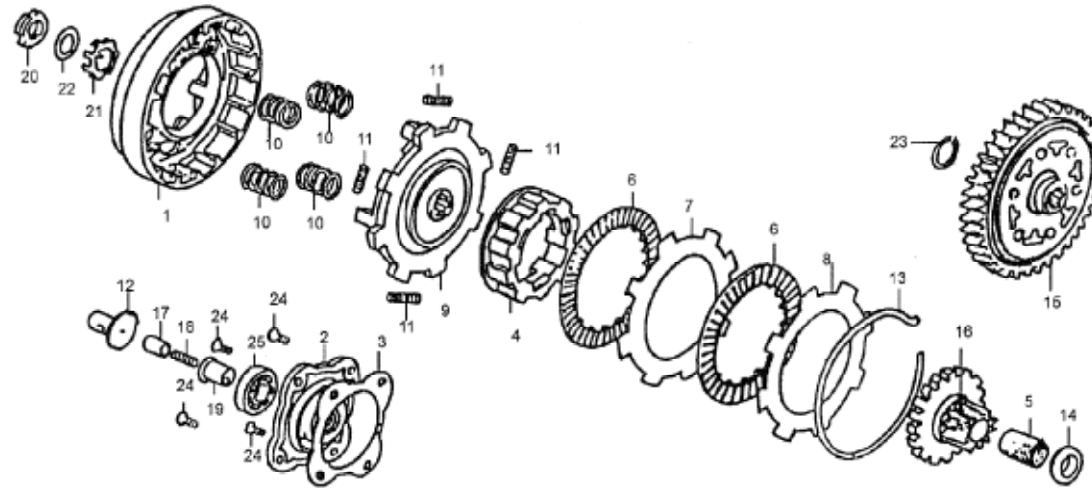

序号 Ref.No.	零部件代号 Part No.	零部件名称及规格	Part Name And Standard	数量 Quantity	备注 Remark
16	LX147FM.06-3	主动齿轮	Driving gear	1	
17	LX147FM.06-17	通油管	Oil pipe in	1	
18	LX147FM.06-18	通油套管弹簧	Spring	1	
19	LX147FM.06-16	通油套管	Guide pipe	1	
20	LX147FM.06-11	圆螺母	Nut	1	
21	LX147FM.06-13	止退垫圈	Washer thrust	1	
22	LX147FM.06-12	碟形垫圈	Washer lock	1	
23	LX147FM.05.01-6	挡圈	Circlip	1	
24	GB819-85	螺钉	Screw	4	
25	GB276-82	轴承 100	Bearing radial ball 100	1	



E-11 曲轴箱、机油泵 (CRANKCASE、OIL PUMP)

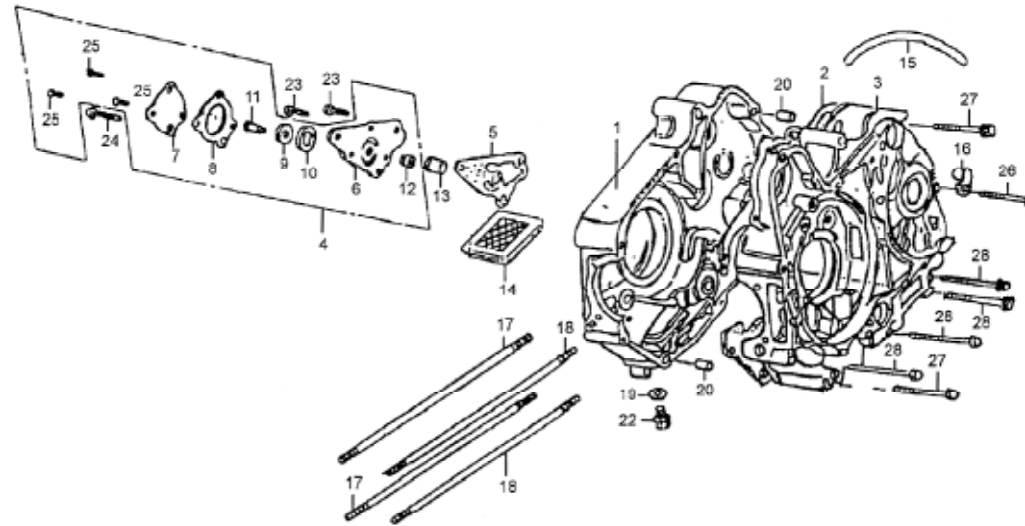

序号 Ref.No.	零部件代号 Part No.	零部件名称及规格	Part Name And Standard	数量 Quantity	备注 Remark
1	101102C-3	右曲轴箱	Crankcase comp, R,(90cc)	1	
1-1	101102C-1	右曲轴箱	Crankcase comp, R,(50cc)	1	
2	01.04.00.01-3	曲轴箱衬垫	Gasket, crankcase(90cc)	1	
2-1	01.04.00.01-1	曲轴箱衬垫	Gasket, crankcase(50cc)	1	
3	101002C-3	左曲轴箱	Crankcase comp, L,(90cc)	1	
3-1	101002C-1	左曲轴箱	Crankcase comp, L,(50cc)	1	
4	01.04.06.00	机油泵	Pump assy, oil	1	
5	01.04.00.10	机油泵衬垫	Gasket, oil pump body	1	
6	01.04.06.01	机油泵体	Body, oil pump	1	
7	01.04.06.04	机油泵盖	Cover, oil pump	1	
8	01.04.06.05	机油泵盖衬垫	Gasket, oil pump cover	1	
9	01.04.06.06	机油泵内转子	Rotor, oil pump, inner	1	
10	01.04.06.07	机油泵外转子	Rotor, oil pump, outer	1	
11	01.04.06.03	机油泵轴	Driveshaft, oil pump	1	
12	01.04.06.02	机油泵轴套	Pin, oil pump lock	1	



E-11 曲轴箱、机油泵 (CRANKCASE, OIL PUMP)

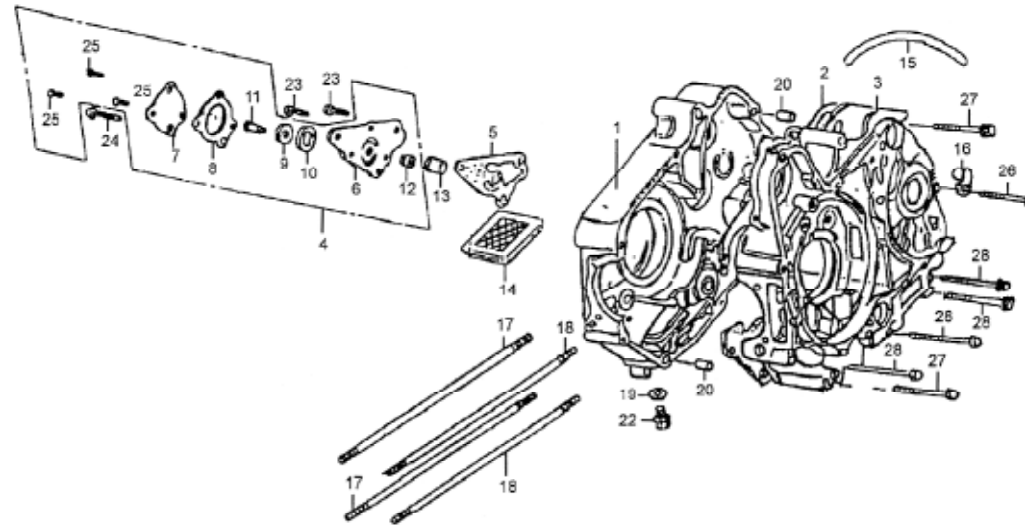

序号 Ref.No.	零部件代号 Part No.	零部件名称及规格	Part Name And Standard	数量 Quantity	备注 Remark
13	01.04.00.09	机油泵链轮轴套	Pivot, oil pump	1	
14	01.04.04.00	机油过滤网组件	Screen, oil filter	1	
15	01.04.00.24	通气管	Tube, breather	1	
16	01.04.00.28	管夹	Clamper, tube	1	
17	01.04.00.07	双头螺栓 A	Bolt A, cylinder stud	2	
18	01.04.00.26	双头螺栓 B	Bolt B, cylinder stud	2	
19	01.04.00.12	垫圈	Washer, drain plug	1	
20	01.04.00.18	定位销 10 × 14	Pin dowel, 10x14	2	
22	01.04.00.11	放油螺塞 M12 × 1.5	Bolt drain 12x1.5	1	
23	Gb818-86	螺钉 M6 × 16	Screw, 6x16	2	
24	BG818-86	螺钉 M6 × 22	Screw, 6x22	1	
25	GB818-86	螺钉 M5 × 10	Screw, psn, 6x10	3	
26	01.04.00.21	凸缘螺栓 M6 × 50	Bolt, flange 6x50	1	
27	01.04.00.19	凸缘螺栓 M6 × 60	Bolt, flange 6x60	2	
28	01.04.00.17	凸缘螺栓 M6 × 65	Bolt, flange 6x65	4	





E-12 活塞、曲轴 (PISTON、CRANKSHAFT)

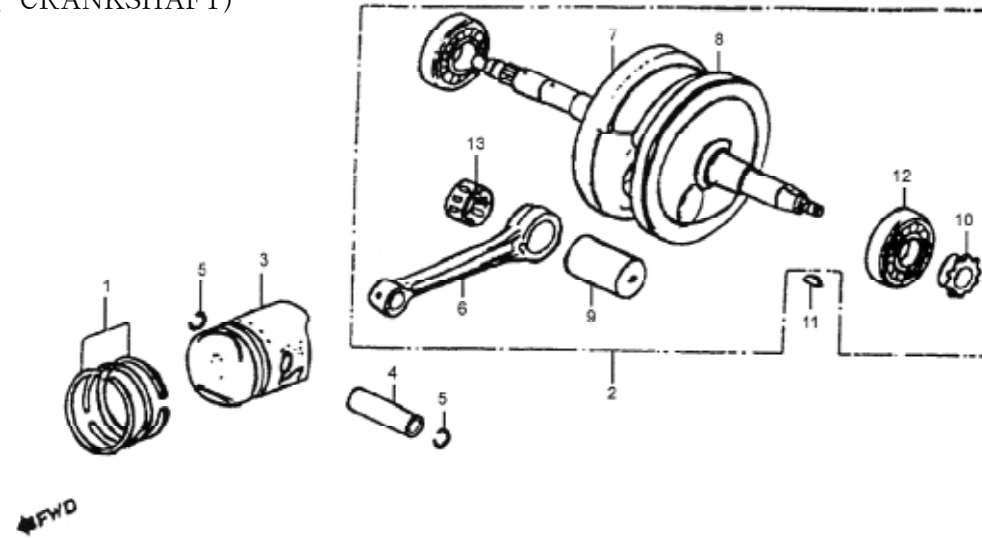

序号 Ref.No.	零部件代号 Part No.	零部件名称及规格	Part Name And Standard	数量 Quantity	备注 Remark
1	05.03.01.08-3 .09-3 .10-3	活塞环组	Ring set,piston(90cc)	1	
1-1	05.03.01.08-1 .09-1 .10-1	活塞环组	Ring set,piston(50cc)	1	
2	07.03.01.00-3	曲柄连杆	Cranshaft comp(90cc)	1	
2-1	07.03.01.00-1	曲柄连杆	Cranshaft comp(50cc)	1	
3	05.03.01.09-3	活塞	Piston(90cc)	1	
3-1	05.03.01.09-1	活塞	Piston(50cc)	1	
4	01.03.01.05-3	活塞销	Pin, piston(90cc)	1	
4-1	01.03.01.05-1	活塞销	Pin, piston(50cc)	1	
5	01.03.01.04	活塞销挡圈	Clip, piston pin	2	
6	05.03.01.06-3	连杆	Rod, connecting(90cc)	1	
6-1	05.03.01.06-1	连杆	Rod, connecting(50cc)	1	



E-12 活塞、曲轴 (PISTON、CRANKSHAFT)

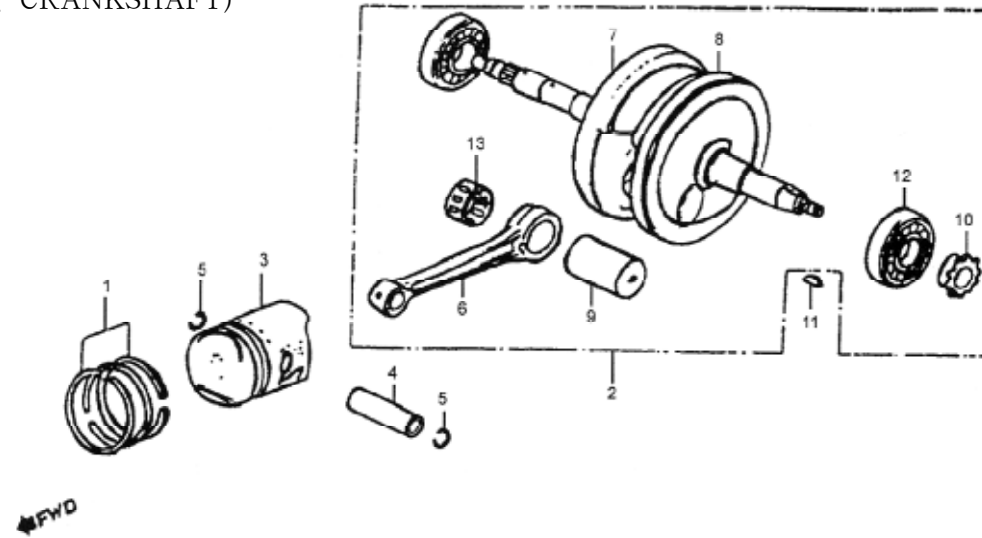

序号 Ref.No.	零部件代号 Part No.	零部件名称及规格	Part Name And Standard	数量 Quantity	备注 Remark
7	07.03.01.11-3	右曲轴组件	Crankshaft, R,(90cc)	1	
7-1	07.03.01.11-1	右曲轴组件	Crankshaft, R,(50cc)	1	
8	07.03.01.02-3	左曲轴	Crankshaft, L,(90cc)	1	
8-1	07.03.01.02-1	左曲轴	Crankshaft, L,(50cc)	1	
9	05.03.01.10-3	曲轴销	Pin, crank(90cc)	1	
9-1	05.03.01.10-1	曲轴销	Pin, crank(50cc)	1	
10	01.03.01.03-3	正时主动链轮	Sprocket, timing(90cc)	1	
10-1	01.03.01.03-1	正时主动链轮	Sprocket, timing(50cc)	1	
11	01.03.01.01-3	半圆键	Key, woodruff(90cc)	1	
11-1	01.03.01.01-1	半圆键	Key, woodruff(50cc)	1	
12	D304 GB276-82-3	轴承 6304	Bearing, radial ball 6304(90cc)	2	
12-1	D304 GB276-82-1	轴承	Bearing, radial ball(50cc)	2	
13	9243/23.1-3	滚针轴承	Needle bearing(90cc)	1	
13-1	9243/23.1-1	滚针轴承	Needle bearing(50cc)	1	



E-13 主轴、副轴 (MAINSHAFT、COUNTERSHAFT)

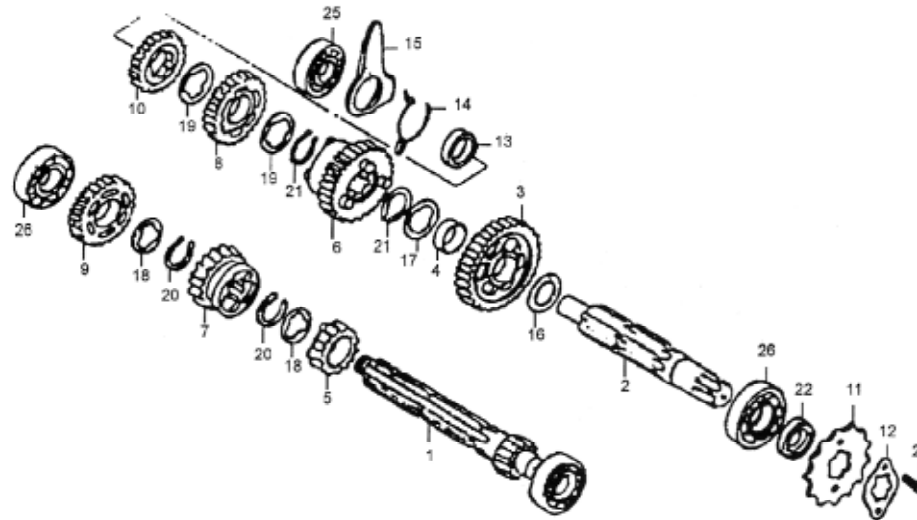

序号 Ref.No.	零部件代号 Part No.	零部件名称及规格	Part Name And Standard	数量 Quantity	备注 Remark
1	01.06.02.02	主轴	Mainshaft	1	
2	07.06.01.05	副轴	Countershaft	1	
3	07.06.01.02	副轴 一挡齿轮	Gear, countershaft low	1	
4	07.06.01.01	衬套 20 × 9	Bush, 20x9	1	
5	07.06.02.03	主轴二挡齿轮	Gear, mainshaft second	1	
6	07.06.01.04	副轴二挡齿轮	Gear, countershaft second	1	
7	07.06.02.04	主轴三挡齿轮	Gear, mainshaft third	1	
8	07.06.01.08	副轴三挡齿轮	Gear, countershaft third	1	
9	07.06.02.05	主轴四挡齿轮	Gear, mainshaft fourth	1	
10	07.06.01.10	副轴四挡齿轮	Gear, countershaft fourth	1	
11	01.06.00.01-3	主动链轮(15齿)	Sprocket, drive(90cc, Z=15)	1	
11-1	01.06.00.01-1	主动链轮(13齿)	Sprocket, drive(50cc, Z=13)	1	
12	01.06.00.02	固定板	Plate, drive sprocket fixing	1	
13	07.06.01.14	衬套	Bush	1	
14	07.06.01.11	卡簧	Spring	1	



E-13 主轴、副轴 (MAINSHAFT、COUNTERSHAFT)

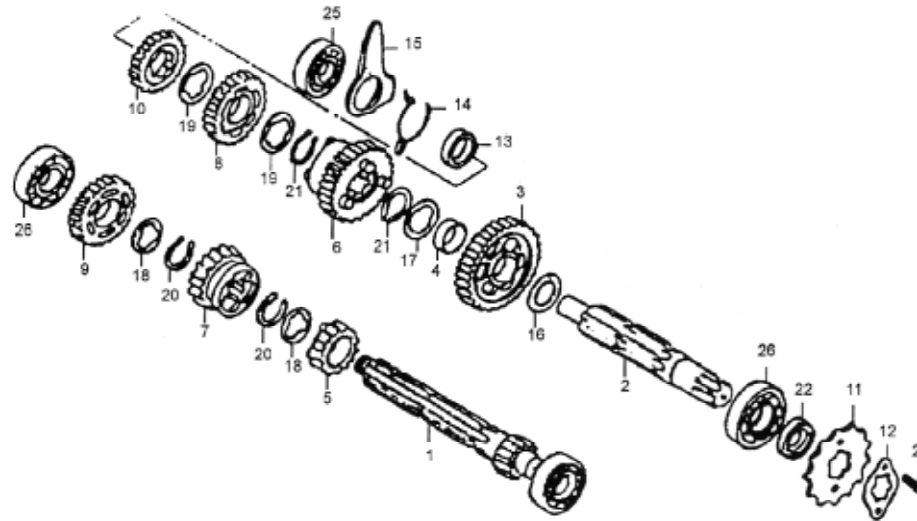

序号 Ref.No.	零部件代号 Part No.	零部件名称及规格	Part Name And Standard	数量 Quantity	备注 Remark
15	07.06.01.12	限位板	Stopper	1	
16	07.06.01.13	止推垫圈 17mm	Washer, thrust, 17mm	1	
17	07.06.01.07	花键垫圈 20mm	Washer, spline, 20mm	1	
18	01.06.01.03	花键垫圈 17mm	Washer, spline, 17mm	2	
19	07.06.01.07	花键垫圈 20mm	Washer, spline, 20mm	2	
20	01.06.01.06	挡圈 17mm	Cir clip, 17mm	2	
21	07.06.01.06	挡圈 20mm	Cir clip, 20mm	2	
22	01.04.14.00	油封 17 × 29 × 5	Oil seal 17x29x5	1	
23	GB5782-86	螺栓 M6 × 8	Bolt hex 6x8	2	
24	GB276-82	轴承 6001	Bearing, radial ball 6001	1	
25	GB276-82	轴承 6201	Bearing, radial ball 6201	1	
26	GB276-82	轴承 6203	Bearing, radial ball 6203	2	



E-14 变速装置 (GEAR SHAFT DRUM SPINDLE)

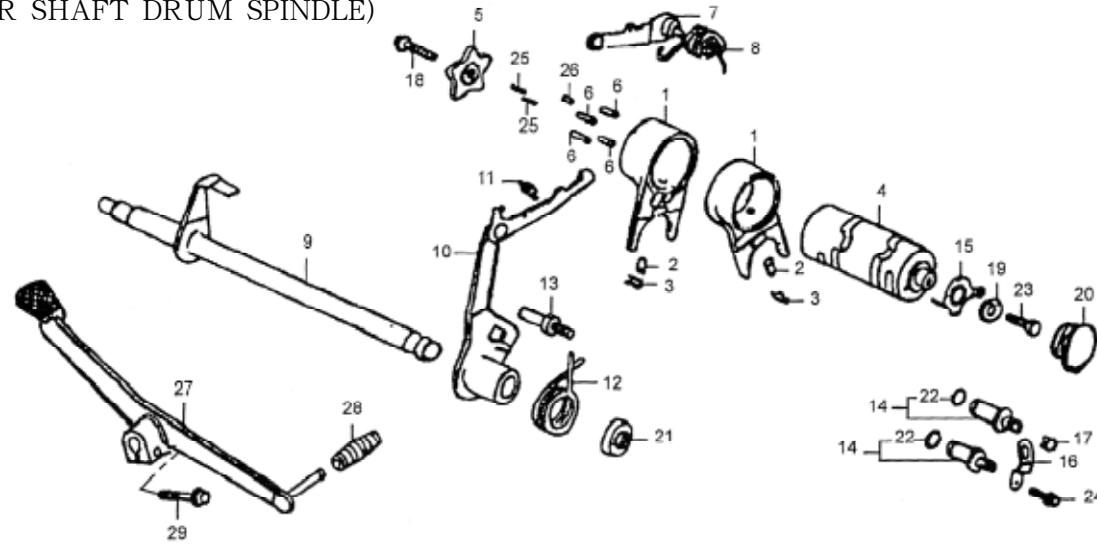

序号 Ref.No.	零部件代号 Part No.	零部件名称及规格	Part Name And Standard	数量 Quantity	备注 Remark
1	01.06.04.04	变速拨叉	Fork, gearshift	2	
2	01.06.04.01	导向销	Pin, gearshift fork guide	2	
3	01.06.04.03	卡簧	Clip, gearshift fork guide pin	2	
4	07.06.04.02	变速凸轮轴	Drum, gearshift	1	
5	07.06.04.06	定位挡板	Plate, gearshift drum stopper	1	
6	07.06.00.03	拨销	Pin, gearshift drum	4	
7	07.04.03.00	定位轮组件	Stopper comp, gearshift drum	1	
8	07.04.00.03	定位轮回位弹簧	Sping, gearshift drum stopper	1	
9	07.07.01.01-3	换挡轴	Gearshift(90cc)	1	
9-1	07.07.01.01-1	换挡轴	Gearshift(50cc)	1	
10	07.07.01.00-3	换挡臂	Spindle comp, gearshift(90cc)	1	
10-1	07.07.01.00-1	换挡臂	Spindle comp, gearshift(50cc)	1	
11	01.07.01.06	换挡臂弹簧	Spring, gearshift arm	1	
12	01.07.01.07	换挡轴回位弹簧	Spring, shift return spring	1	
13	01.04.00.04	回位弹簧定位螺栓	Pin, shift return spring	1	
14	01.04.08.00	挡位开关组件	Contact assy, switch	2	



E-14 变速装置 (GEAR SHAFT DRUM SPINDLE)

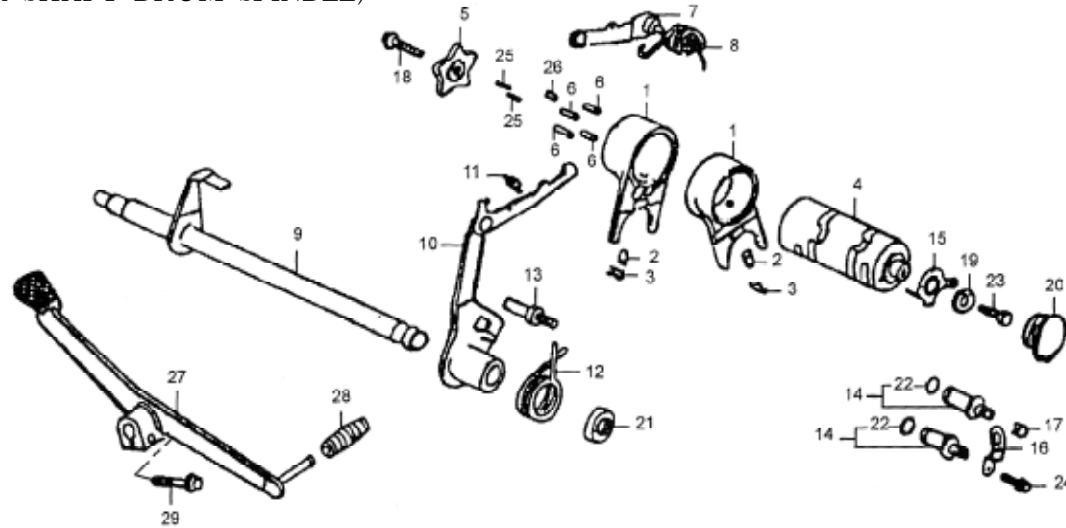

序号 Ref.No.	零部件代号 Part No.	零部件名称及规格	Part Name And Standard	数量 Quantity	备注 Remark
15	07.06.04.05	挡位开关接触片	Rotor switch	1	
16	07.04.00.23	固定板	Plate, contact fixing	1	
17	140099	挡位开关帽	Cap, switch	1	
18	GB5787-86	螺栓 M6 × 16	Bolt, dowel, 6 × 16	1	
19	01.04.00.05	垫圈	Washer, gearshift drum side	1	
20	01.04.00.22	橡胶螺栓	Plug, rubber	1	
21	01.04.13.00	油封 11.6 × 24 × 10	oil seal 11.6 × 24 × 10	1	
22	01.04.08.01	O形圈 7 × 1.7	O-ring 7 × 1.7	2	
23	GB5782-86	螺栓 M6 × 12	Bolt, hex, 6 × 16	1	
24	GB5782-86	凸缘螺栓 M6 × 12	Screw, flange, 6 × 12	1	
25	140089	滚针 $\varnothing 3 \times 8.5$	Roller, 3 × 8.5	2	
26	140088	滚针 $\varnothing 4 \times 10$	Roller, 4 × 10	1	
27	07.07.02.00	变档划板	Pedal, gear change	1	
28	140087	胶套	Rubber, change pedal	1	
29	GB5782-86	螺栓 M6 × 20	Bolt, hex, 6 × 20	1	



E-15 起动装置 (STARTER)

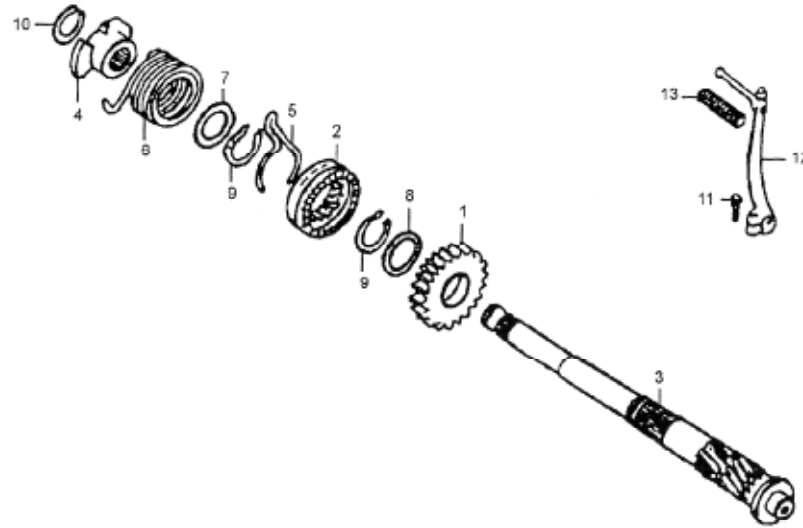

序号 Ref.No.	零部件代号 Part No.	零部件名称及规格	Part Name And Standard	数量 Quantity	备注 Remark
1	07.08.01.01	起动齿轮	Gear, kick starter	1	
2	01.08.01.03	起动棘轮	Ratchet, kick starter	1	
3	07.08.01.07	起动轴	Spindle, kick starter	1	
4	01.08.01.06	起动轴弹簧座	Retainer, kick spring	1	
5	07.08.01.13	起动齿轮卡弹簧	Spring, kick starter ratchet	1	
6	07.08.01.05	起动轴回位弹簧	Spring, kick starter	1	
7	01.08.01.09	垫圈 17mm	Washer, 17mm	1	
8	01.08.01.12	止推垫圈 20mm	washer, thrust,20mm	1	
9	01.08.01.11	挡圈 20mm	Cir clip 20mm	2	
10	01.08.01.08	挡圈 16mm	cir clip 16mm	1	
11	GB5782-86	螺栓 M6x22	Bolt, hex, 6x22	1	
12	07.08.02.00	起动踏杆	Arm, kick starter	1	
13	07.08.02.03	踏杆橡胶套	Rubber, kick starter	1	



E-16 起动电机 (MOTOR, STARTER)

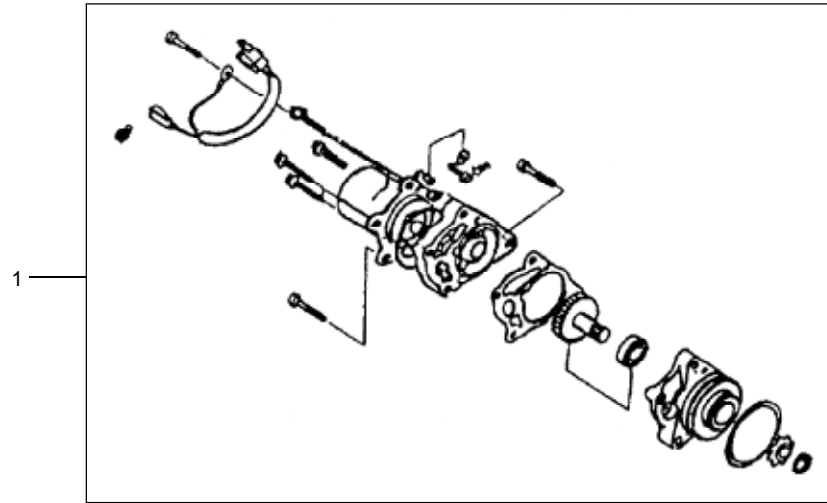

序号 Ref.No.	零部件代号 Part No.	零部件名称及规格	Part Name And Standard	数量 Quantity	备注 Remark
1	02.12.00.00	起动电机总成	Starting motor assy	1	





E-17 化油器 (CARBURETOR COMP)

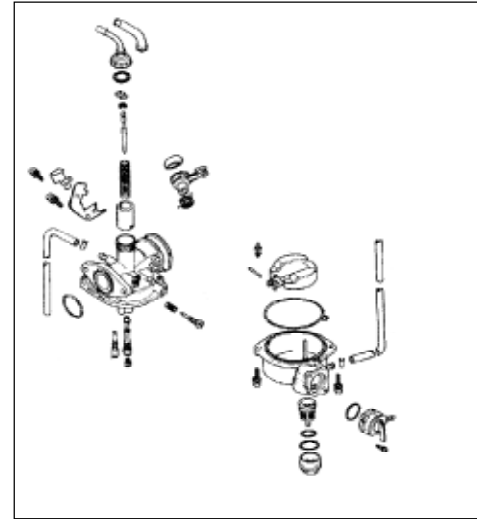
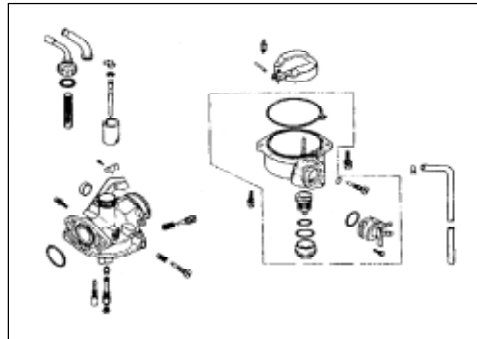

序号 Ref.No.	零部件代号 Part No.	零部件名称及规格	Part Name And Standard	数量 Quantity	备注 Remark
1	13200-Z1000-1	化油器	CARBURETOR(50cc)	1	
2	13200-Z1000	化油器	CARBURETOR(90cc)	1	

**ST50 ST90**



**PARTS CATALOGUE — VEHICLE**













# SKYTEAM ST50 ST90

## PARTS CATALOGUE — VEHICLE

序	件号	英文名称	中文名称	数量	ST90	ST50
1	41100-Z1000	Frame ASSY	车架组件	1	✓	✓
2	41222-Z1000	Frame cover	车架盖板	1	✓	✓
3	GB845-85 ST4, 2x16-F-H-Zn, DJ	Screw	自攻螺钉	2	✓	✓
4	41220-Z1000	Cable holder	线架	2	✓	✓
5	46110-Z1000-1	Rear carrier (Dubble seats)	后拉手	1	✓	✓
6	42310-Z1000	Side stand ASSY	单撑组件	1	✓	✓
7	42312-Z1000	Side stand spring	单撑外弹簧	1	✓	✓
8	42321-Z1000	Inner spring	单撑内弹簧	1	✓	✓
9	43510-Z1000	Foot rest ASSY	前脚踏杆组件	1	✓	✓
9-1	GB5783-86 M8X20-Zn, DJ	Bolt	螺栓	4	✓	✓
9-2	GB859-87 8-Zn, DJ	Lock washer	弹簧垫圈	4	✓	✓
9-3	GB5787-86 M8X20-Zn, DJ	Bolt	螺栓	1	✓	✓
9-4	GB5787-86 M8X25-Zn, DB	Bolt	螺栓	1	✓	✓
9-5	GB5287-86 8-140Hv-Zn, DB	Washer	特大垫圈	1	✓	✓
10	46110-Z1000	Rear carrier (Single seat)	后拉手	1	✓	✓
10-1	GB5787-86 M8X16-Zn, DJ	Bolt	螺栓	3	✓	✓
10-2	GB5787-86 M8X20-Zn, DJ	Bolt	螺栓	1	✓	✓
10-3	46123-Z1000	Rubber Pad	缓冲垫圈	1	✓	✓
10-4	GB5787-86 M8X25-Zn, DJ	Bolt	螺栓	1	✓	✓
10-5	46125-Z1000	Spacer	台阶衬套	1	✓	✓
10-6	GB96-858-Z/40HV-Zn, DJ	Washer	特大垫圈	1	✓	✓
11	38160-Y1000	Rear reflector	后反射器	1	✓	✓
11-1	GB6170-86 M5-Zn, DH	Nut	螺母	1	✓	✓
12	42311-Y1000	Bolt	单撑螺栓	1	✓	✓
13	63112-Z1000	Rear fender	后挡泥板	1	✓	✓
14	61261-Z1000	Plate	链条涨紧器安装板	1	✓	✓
15	61262-Z1000	Rubber	链条涨紧器缓冲块	1	✓	✓
16	61263-Z1000	Spring	链条涨紧器扭簧	1	✓	✓
17	61264-Z1000	Plate	链条涨紧器压板	1	✓	✓

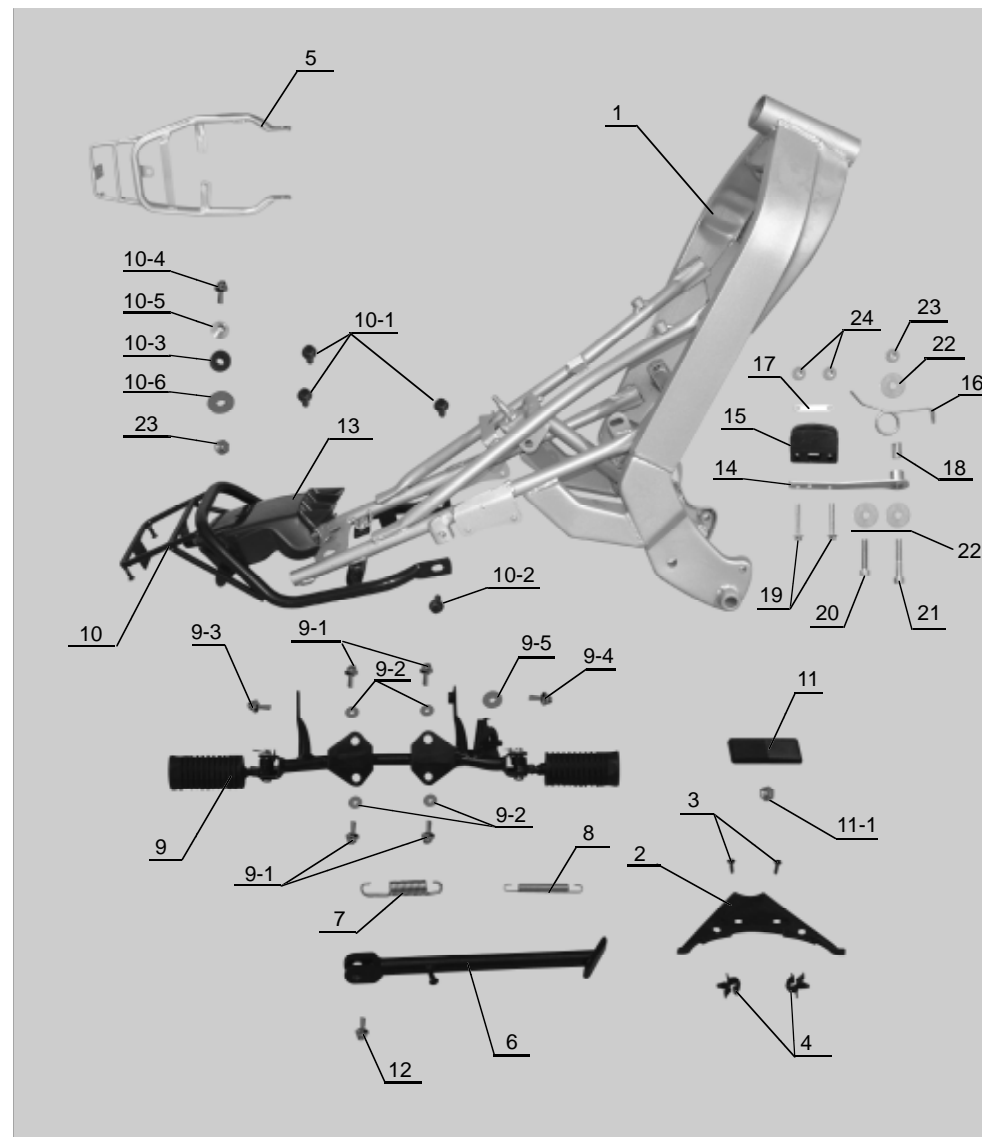







# SKYTEAM ST50 ST90

## PARTS CATALOGUE — VEHICLE

序	件号	英文名称	中文名称	数量	ST90	ST50
1	190003	Rim, RH	右轮圈	1	✓	✓
2	190004	Rim, LH	左轮圈	1	✓	✓
3	GB5783-86 M6X14-Zn.DB	Bolt	螺栓	4	✓	✓
4	GB97.1-85 6-140Hv-Zn.DB	Washer	垫圈	4	✓	✓
5	GB6187-86 M6-Zn.DB	Nut	螺母	4	✓	✓
6	54111-Z1000	Drum, front hub	前轮鼓	1	✓	✓
7	GB5783-86 M8X25-Zn.DB	Bolt	螺栓	4	✓	✓
8	GB859-87 8-Zn.DB	Lock washer	弹簧垫圈	4	✓	✓
9	CJ70A-210221	Nut	螺母	4	✓	✓
10	54121-Z1000	Front wheel(L) bush	前轮左衬套	1	✓	✓
11	54123-Z1000	Bushing	前轮轴承衬套	1	✓	✓
12	09284-C0600-1	Oil seal	前轮密封圈	1	✓	✓
13	60301 GB278-82	Bearing	前轮轴承	2	✓	✓
14	54600-Z1000	Speedometer clutch	变速器总成	1	✓	✓
15	59000-Z1000	Front brake ASSY	前液压制动器总成	1	✓	✓
15-1	59312-Z1000	Brake pad	摩擦片	2	✓	✓
15-2	GB5787-86 M8X32-Zn.DJ	Bolt	制动钳体安装螺栓	2	✓	✓
16	59489-A0400	Clip	油管夹	1	✓	✓
16-1	GB5787-86 M6X12-Zn.DJ	Bolt	螺栓	1	✓	✓
17	59242-A0300	Clip	油管固定夹	1	✓	✓
18	55100-Z1000	Tire	前轮外胎	1	✓	✓
19	55200-Z1000	Tube, inner	前轮内胎	1	✓	✓
20	54711-Z1000	Axle, front hub	前轮轴	1	✓	✓
21	GB6187-86 M12X1.25-Zn.DB	Self-locking nut	自锁螺母	1	✓	✓
22	59412-Z1000	Brake disc	前刹车盘	1	✓	✓
22-1	58412-C0200	Bolt	前刹车安装螺栓	3	✓	✓
23	59311-Z1000	Front brake lever	前刹车手柄	1	✓	✓
24	59480-Z1000	Front brake pump(Upper)	前刹上泵	1	✓	✓
25	59210-Z1000	Front brake hose	前刹油管	1	✓	✓
26	59460-Z1000	Front brake pump(Down)	前刹下泵	1	✓	✓

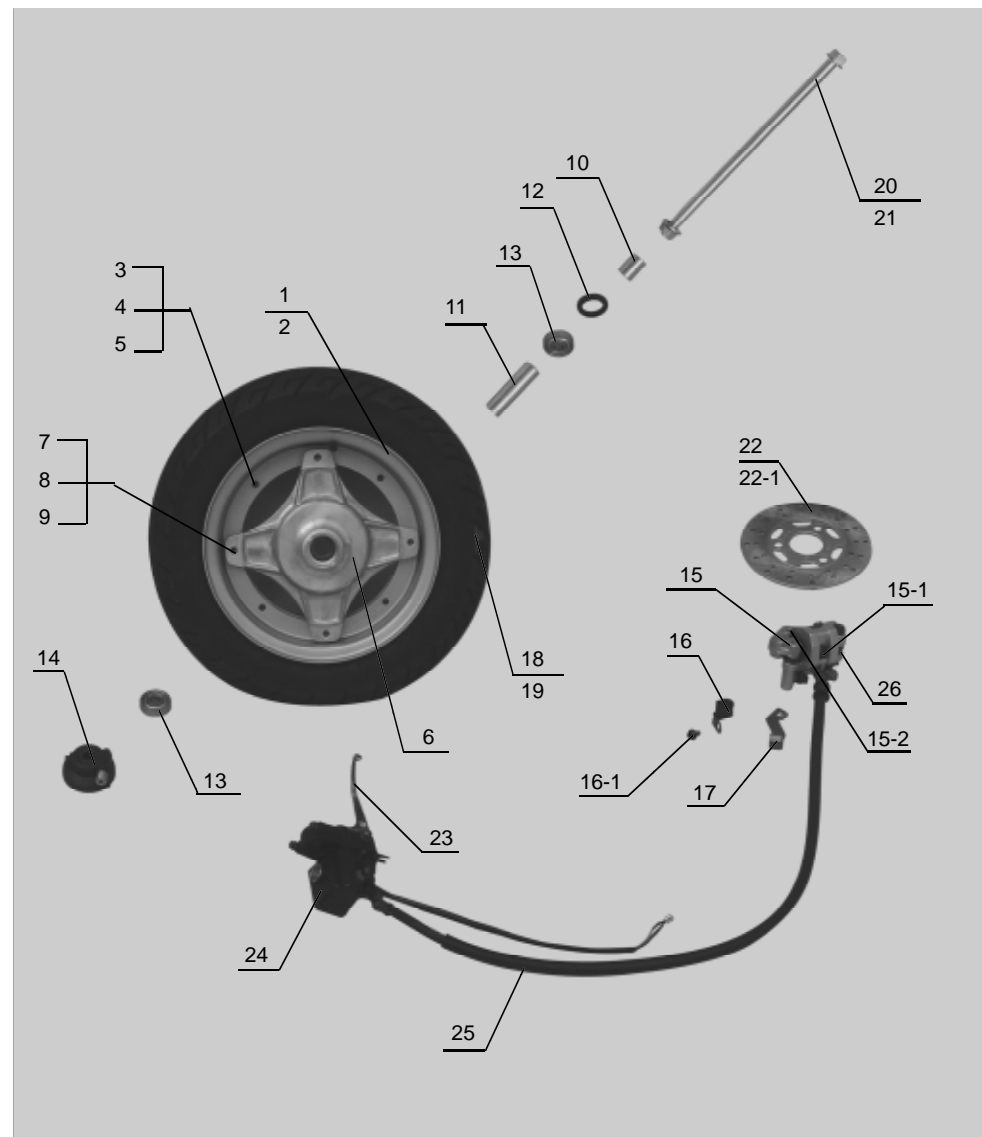





# SKYTEAM ST50 ST90

## PARTS CATALOGUE — VEHICLE

序	件号	英文名称	中文名称	数量	ST90	ST50
1	61100-Z1000	Swinging arm ASSY	后平叉组件	1	✓	✓
1-1	09319-Z1000	Rubber cushioning	后叉缓冲器	2	✓	✓
1-2	61222-Z1000	Spacer	后平叉中间衬套	1	✓	✓
2	61273-Z1000	Chain Support	链条防缓冲板	1	✓	✓
3	61211-Z1000	Shaft,pivot	后叉轴	1	✓	✓
4	GB6187-86 M12X1.25-Zn,DB	Nut	后叉螺母	1	✓	✓
5	45100-Z1000	Seat ASSY(Single seat)	座垫总成	1	✓	✓
5-1	GB96-86 6-140HN-Zn,DJ	Washer	大垫圈	1	✓	✓
5-2	46121-Z1000	Rubber Pad	缓冲垫圈	1	✓	✓
5-3	46122-Z1000	Spacer	衬套	1	✓	✓
5-4	GB6170-86 M6-Zn,DJ	Nut	螺母	1	✓	✓
5-5	GB859-86 M6-Zn,DB	Lock washer	弹簧垫片	1	✓	✓
6	62100-Z1000	Shock absorber ASSY	后减震器总成	1	✓	✓
6-1	GB5787-86 M10X1.25X35-Zn,DJ	Bolt	后减螺栓	2	✓	✓
7	68711-Z1000	Name plate	铭牌	1	✓	X
	68711-Z1000-1	Name plate	铭牌	1	X	✓
7-1	GB827-86 2X5-L4	River	铆钉	4	✓	✓
8	68712-Z1000	REFIT-PROOF EMBLEM	防窜改牌	1	✓	X
	68712-Z1000-1	REFIT-PROOF EMBLEM	防窜改牌	1	X	✓
9	61410-D0300	Adjuster,chain	链条调节器	2	✓	✓
10	61421-C0200	Adjuster cover	链条调节器盖板	2	✓	✓
11	GB6170-86 M8-Zn,DB	Nut	螺母	4	✓	✓
12	45100-Z1000-1	Seat ASSY(Dubble seats)	座垫总成	1	✓	✓
13	43600-Z1000	Left foot rest, rear(Dubble seats)	后左脚踏组件	1	✓	✓
14	43700-Z1000	Right foot rest, rear(Dubble seats)	后右脚踏组件	1	✓	✓

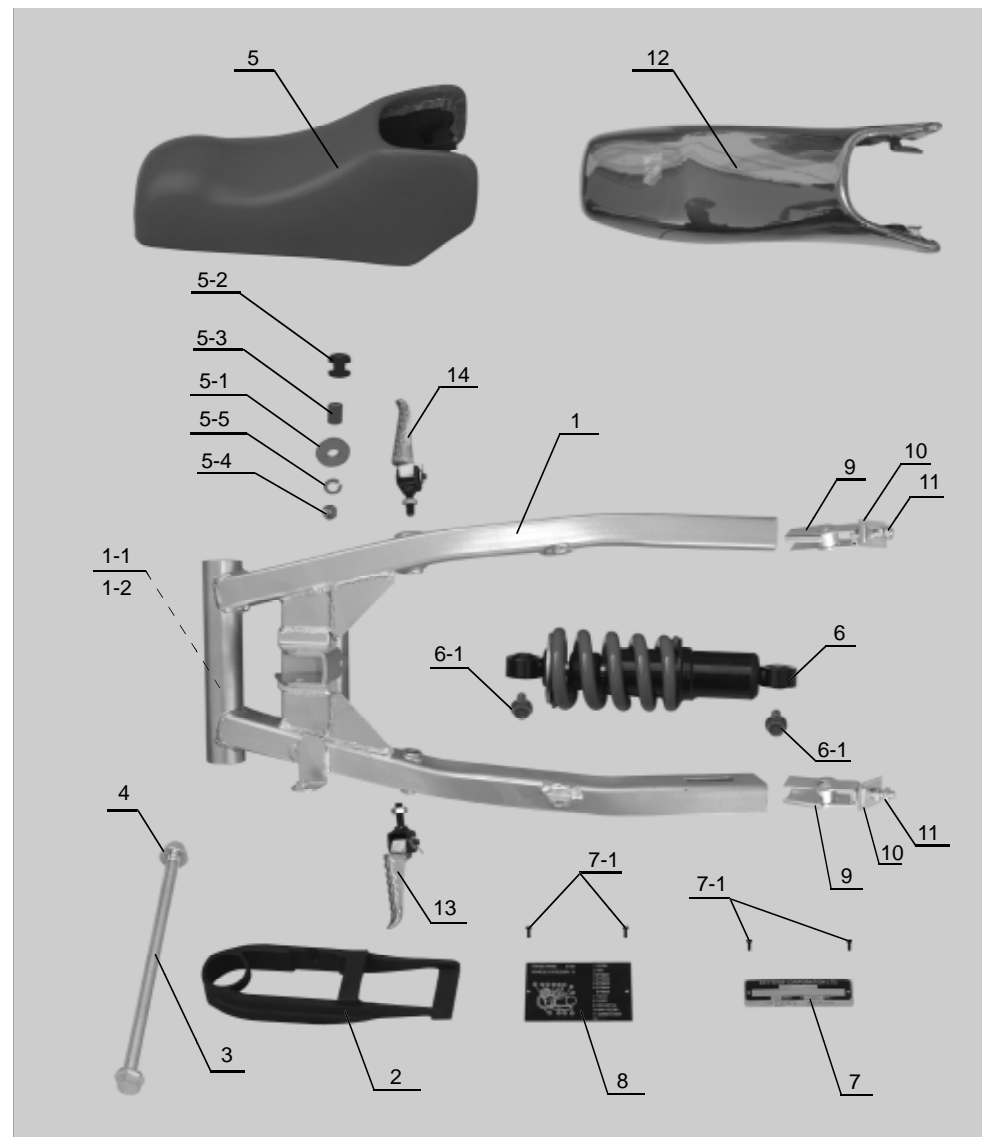



# SKYTEAM ST50 ST90

## PARTS CATALOGUE — VEHICLE

序	件号	英文名称	中文名称	数量	ST90	ST50
1	65100-Z1000	Tire	后轮外胎	1	✓	✓
2	65200-Z1000	Tube, inner	后轮内胎	1	✓	✓
3	64511-A1500	Sprocket	后链轮(Z=42)	1	X	✓
	140200	Sproket	后链轮(Z=36)	1	✓	X
4	GB894.1-86 50-Y	Thrust washer	档圈	1	✓	✓
5	210214	Rubber cushion	胶块	4	✓	✓
6	140027	Dust cover	防尘盖	1	✓	✓
7	64142-Z1000	Rim, LH	后轮辋左片	1	✓	✓
8	64141-Z1000	Rim, RH	后轮辋右片	1	✓	✓
9	GB5783-86 M6X14Zn.DB	Bolt	螺栓	4	✓	✓
10	GB97.1-85 6-140HVZN.DB	Washer	平垫圈	4	✓	✓
11	GB6187-86 M6-Zn.DB	Nut	螺母	4	✓	✓
12	210201	Drum, rear hub	后轮鼓	1	✓	✓
13	GB5783-86 M8X25-Zn.DB	Bolt	螺栓	4	✓	✓
14	CJ70A-210221	Nut	螺母	4	✓	✓
15	GB859-87 8-Zn.DB	Lock washer	弹簧垫圈	4	✓	✓
16	64711-Z1000	Axle, rear	后轮轴	1	✓	✓
17	GB6187-86 M12X1.25-Zn.DB	Self-locking nut	自锁螺母	1	✓	✓
18	64122-Z1000	Right spacer, rear hub	后轮右轴套	1	✓	✓
19	64121-Z1000	Left spacer, rear hub	后轮左轴套	1	✓	✓
20	60301 GB278-82	Bearing	轴承	2	✓	✓
21	210207	Bushing	衬管	1	✓	✓
22	210213	Oil seal	密封皮碗	1	✓	✓
23	210202	Panel, rearhub	后制动鼓盖	1	✓	✓
24	210206	Cam, brake	后制动凸轴轮	1	✓	✓
25	210215	Level, Cam washer	后制动摇臂	1	✓	✓
25-1	GB5783-86 M6X38-Zn.DJ	Bolt	螺栓	1	✓	✓
25-2	GB6170-86 M6-Zn.DJ	Nut	螺母	1	✓	✓
26	CJ70A-210203	Shoe, brake	制动块组合	2	✓	✓

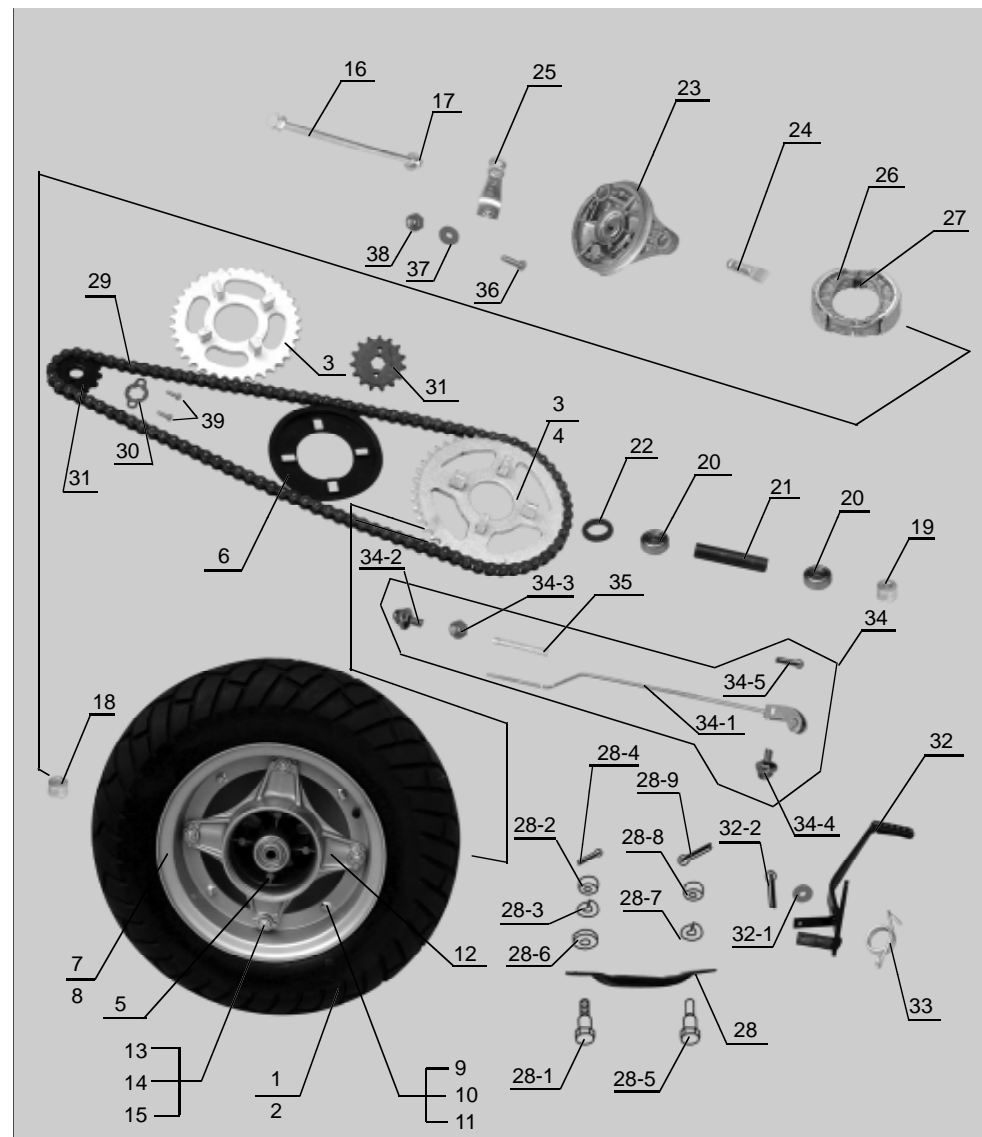



# SKYTEAM ST50 ST90

## PARTS CATALOGUE — VEHICLE

序	件号	英文名称	中文名称	数量	ST90	ST50
27	210210	Spring	制动弹簧	2	✓	✓
28	65310-Z1000	Pandel ,brake	后轮扭力杆	1	✓	✓
28-1	09111-08012	Bolt	螺栓	1	✓	✓
28-2	GB6172-86 M8-Zn.DB	Nut	螺母	1	✓	✓
28-3	GB859-87 8-Zn.DB	Lock washer	弹簧垫圈	1	✓	✓
28-4	GB91-86 2X20-Zn.DB	Cotter pin	开口销	1	✓	✓
28-5	700006	Bolt	螺栓	1	✓	✓
28-6	GB97.1-85 8-140Hv-Zn.DJ	Washer	垫圈	1	✓	✓
28-7	GB93-87 10-Y	Lock washer	弹簧垫圈	1	✓	✓
28-8	GB6170-86 M8-Zn.DC	Nut	螺母	1	✓	✓
28-9	GB91-86 2X16-Zn.DC	Cotter pin	开口销	1	✓	✓
29	08MA-100 GB/T14214-93	Chain	输出轮条	1	X	✓
	08MA-102 GB/T/4214-93	Chain	输出轮条	1	✓	X
30	140012	Thrust washer	输出链轮挡片	1	✓	✓
31	140011 (Z=15)	Sprocket	输出链轮	1	✓	X
	70-1060001 (Z=13)	Sprocket	输出链轮	1	X	✓
31-1	GB5783-86 M6X8-Zn.DC	Bolt	输出链轮安装螺栓	2	✓	✓
32	43110-Z1000	Rear brake Pandal ASSY	后制动踏杆组件	1	✓	✓
32-1	GB97.1-85 16-140Hv-Zn.DJ	Washer	平垫圈	1	✓	✓
32-2	GB91-86 3.2X26-Zn.DB	Cotter pin	开口销	1	✓	✓
33	43121-Z1000	Spring	扭簧	1	✓	✓
34	43300-Z1000	Rod,brake ASSY	后制动拉杆总成	1	✓	✓
34-1	43310-Z1000	Read brake rod	后制动拉杆组件	1	✓	✓
34-2	210406	Pin	传动销	1	✓	✓
34-3	210405	Nut	制动器调节螺母	1	✓	✓
34-4	43511-C0200	Pin	圆柱销钉	1	✓	✓
34-5	GB91-862X16-Zn.DB	Cotter pin	开口销	1	✓	✓
35	210401	Spring	后制动拉杆调节弹簧	1	✓	✓
36	GB5787-86 M6X35-Zn.DB	Bolt	螺栓	1	✓	✓

